



Digital Transmission Content Protection Specification Volume 1 (Informational Version)

Hitachi, Ltd.

Intel Corporation

Panasonic Corporation

Sony Corporation

Toshiba Corporation

Revision 1.71

February 4, 2015

Preface

Notice

THIS DOCUMENT IS PROVIDED "AS IS" WITH NO WARRANTIES WHATSOEVER, INCLUDING ANY WARRANTY OF MERCHANTABILITY, NONINFRINGEMENT, FITNESS FOR ANY PARTICULAR PURPOSE, OR ANY WARRANTY OTHERWISE ARISING OUT OF ANY PROPOSAL, SPECIFICATION OR SAMPLE. Hitachi, Intel, Panasonic, Sony, and Toshiba (collectively, the "5C") disclaim all liability, including liability for infringement of any proprietary rights, relating to use of information in this specification. No license, express or implied, by estoppel or otherwise, to any intellectual property rights is granted herein.

Some portions of this document, identified as "Draft" are in an intermediate draft form and are subject to change without notice. Adopters and other users of this Specification are cautioned these portions are preliminary, and that products based on it may not be interoperable with the final version or subsequent versions thereof.

Copyright © 1997 - 2015 by Hitachi, Ltd., Intel Corporation, Panasonic Corporation, Sony Corporation, and Toshiba Corporation (collectively, the "5C"). Third-party brands and names are the property of their respective owners.

Intellectual Property

Implementation of this specification requires a license from the Digital Transmission Licensing Administrator.

Contact Information

Feedback on this specification should be addressed to dtla-comment@dtcp.com.

The Digital Transmission Licensing Administrator can be contacted at dtla-manager@dtcp.com.

The URL for the Digital Transmission Licensing Administrator web site is: <http://www.dtcp.com>.

Printing History:

2000-07-14	Digital Transmission Content Protection Specification Volume 1 Revision 1.1
2002-02-25	Digital Transmission Content Protection Specification Volume 1 Revision 1.2a
2004-01-07	Digital Transmission Content Protection Specification Volume 1 Revision 1.3
2005-02-28	Digital Transmission Content Protection Specification Volume 1 Revision 1.4
2007-06-15	Digital Transmission Content Protection Specification Volume 1 Revision 1.5
2007-10-01	Digital Transmission Content Protection Specification Volume 1 Revision 1.51
2010-03-19	Digital Transmission Content Protection Specification Volume 1 Revision 1.6
2010-09-09	Digital Transmission Content Protection Specification Volume 1 Revision 1.61
2011-12-14	Digital Transmission Content Protection Specification Volume 1 Revision 1.7
2012-04-23	Digital Transmission Content Protection Specification Volume 1 Revision 1.7ED1
2013-06-05	Digital Transmission Content Protection Specification Volume 1 Revision 1.7ED2

Table of Contents

PREFACE	2
NOTICE	2
INTELLECTUAL PROPERTY	2
CONTACT INFORMATION.....	2
CHAPTER 1 INTRODUCTION	9
1.1 PURPOSE AND SCOPE	9
1.2 OVERVIEW	9
1.3 REFERENCES	11
1.4 ORGANIZATION OF THIS DOCUMENT	12
1.5 STATE MACHINE NOTATION	13
1.6 NOTATION	13
1.7 NUMERICAL VALUES	13
1.8 BYTE BIT ORDERING.....	14
1.9 PACKET FORMAT	14
1.10 TREATMENT OF PORTIONS OF THE SPECIFICATION MARKED “NOT ESTABLISHED”	14
CHAPTER 2 ABBREVIATIONS	15
2.1 ALPHABETICAL LIST OF ABBREVIATIONS AND ACRONYMS.....	15
CHAPTER 3 THE DIGITAL TRANSMISSION CONTENT PROTECTION SYSTEM	17
3.1 CONTENT SOURCE DEVICE.....	17
3.2 CONTENT SINK DEVICE	18
CHAPTER 4 FULL AUTHENTICATION	20
4.1 INTRODUCTION	20
4.2 NOTATION	20
4.2.1 <i>Defined by the DTLA</i>	20
4.2.1.1 General	20
4.2.1.2 For Device X.....	20
4.2.2 <i>Notation used during Full Authentication</i>	20
4.2.3 <i>Device Certificate Formats</i>	21
4.2.3.1 Baseline Format	21
4.2.3.2 Extended Format Fields (NOT ESTABLISHED ² Components of the Device Certificate).....	22
4.3 MANUFACTURE OF COMPLIANT DEVICES.....	22
4.4 CRYPTOGRAPHIC FUNCTIONS	23
4.4.1 <i>SHA-1 (Secure Hash Algorithm, revision 1)</i>	23
4.4.2 <i>Random Number Generator</i>	23
4.4.3 <i>Elliptic Curve Cryptography (ECC)</i>	23
4.4.3.1 Elliptic Curve Digital Signature Algorithm (EC-DSA)	24
4.4.3.2 Elliptic Curve Diffie-Hellman (EC-DH).....	25
4.4.3.3 Implementation of the Elliptic Curve Cryptosystem	25
4.5 PROTOCOL FLOW	26
4.5.1 <i>Protocol Flow Overview</i>	26
CHAPTER 5 RESTRICTED AUTHENTICATION	27
5.1 INTRODUCTION	27
5.2 NOTATION	27
5.2.1 <i>Defined by the DTLA</i>	27
5.2.1.1 General	27
5.2.1.2 For Device X	28

5.2.2	<i>Notation used during Restricted Authentication</i>	28
5.2.3	<i>Device Certificate Format</i>	29
5.2.4	<i>Random Number Generator</i>	29
5.3	PROTOCOL FLOW	30
5.3.1	<i>Protocol Flow Overview</i>	30
CHAPTER 6 CONTENT CHANNEL MANAGEMENT AND PROTECTION		31
6.1	INTRODUCTION	31
6.2	CONTENT MANAGEMENT KEYS	31
6.2.1	<i>Exchange Key (K_X) and Session Exchange Key (K_S)</i>	31
6.2.1.1	Exchange Keys (K_X)	31
6.2.1.2	Session Exchange Keys (K_S)	31
6.2.2	<i>Content Key (K_C)</i>	32
6.2.2.1	K_C For M6	32
6.2.2.1.1	M6 Related Key and Constant Sizes	32
6.2.2.2	K_C for AES-128	33
6.2.2.2.1	AES-128 Related Key and Constant Sizes	33
6.2.3	<i>Alternate Content Key (AK_C)</i>	34
6.2.3.1	AK_C for M6	34
6.2.3.1.1	M6 Related Key and Constant Sizes	34
6.2.3.2	AK_C for AES-128	35
6.2.3.2.1	AES-128 Related Key and Constant Sizes	35
6.3	PROTOCOL FLOW	36
6.3.1	<i>Establishing Exchange Key</i>	36
6.3.2	<i>Establishing Session Exchange Key</i>	36
6.3.3	<i>Establishing Content Keys</i>	37
6.3.4	<i>Odd/Even Bit</i>	38
6.4	COPY CONTROL INFORMATION (CCI)	38
6.4.1	<i>Embedded CCI</i>	38
6.4.1.1	DTCP_Descriptor for MPEG-TS	38
6.4.1.2	Content Management Information (CMI)	39
6.4.2	<i>Encryption Mode Indicator (EMI)</i>	39
6.4.3	<i>Relationship between Embedded CCI and EMI</i>	40
6.4.4	<i>Treatment of EMI/Embedded CCI for Audiovisual Device Functions</i>	41
6.4.4.1	Format-cognizant source function	41
6.4.4.2	Format-non-cognizant source function	41
6.4.4.3	Format-cognizant recording function	42
6.4.4.4	Format-cognizant sink function	42
6.4.4.5	Format-non-cognizant recording function	42
6.4.4.6	Format-non-cognizant sink function	42
6.4.5	<i>Treatment of EMI/Embedded CCI Audio Device Functions</i>	43
6.4.5.1	Embedded CCI for audio transmission	43
6.4.5.2	Relationship between Embedded CCI and EMI	43
6.4.5.3	Audio-Format-cognizant source function	43
6.4.5.4	Audio-Format-non-cognizant source function	43
6.4.5.5	Audio-Format-cognizant recording function	44
6.4.5.6	Audio-Format-cognizant sink function	44
6.4.5.7	Audio-Format-non-cognizant recording function	44
6.4.5.8	Audio-Format-non-cognizant sink function	44
6.5	COMMON DEVICE CATEGORIES	44
6.6	CONTENT CHANNEL CIPHERS	45
6.6.1	<i>Baseline Cipher</i>	45
6.6.2	<i>Optional Cipher (NOT ESTABLISHED²)</i>	45
6.6.2.1	AES-128 Cipher	45
6.6.3	<i>Content Encryption Formats</i>	46
6.6.3.1	For M6	46

6.6.3.2	For AES-128.....	46
6.7	ADDITIONAL FUNCTIONS.....	47
6.7.1	<i>Move Function</i>	47
6.7.2	<i>Retention Function</i>	47
CHAPTER 7 SYSTEM RENEWABILITY		48
7.1	INTRODUCTION.....	48
7.1.1	<i>SRM Message Components and Layout</i>	48
7.1.1.1	Certificate Revocation List (CRL).....	49
7.1.1.2	DTLA EC-DSA Signature.....	49
7.1.2	<i>SRM Scalability</i>	50
7.2	UPDATING SRMS.....	50
7.2.1	<i>Device-to-Device Update and State Machines</i>	51
7.2.1.1	Updating a Device's SRM from Another Compliant Device.....	51
CHAPTER 8 AV/C DIGITAL INTERFACE COMMAND SET EXTENSIONS		52
8.1	INTRODUCTION.....	52
8.2	SECURITY COMMAND.....	52
8.3	AKE COMMAND.....	52
8.3.1	<i>AKE control command</i>	53
8.3.2	<i>AKE status command</i>	55
8.3.3	<i>AKE_ID dependent field (AKE_ID = 0)</i>	56
8.4	BUS RESET BEHAVIOR.....	58
8.5	ACTION WHEN UNAUTHORIZED DEVICE IS DETECTED DURING AUTHENTICATION.....	58
8.6	AUTHENTICATION AV/C COMMAND FLOWS.....	59
8.6.1	<i>Figure Notation</i>	59
8.6.2	<i>Full Authentication Command Flow</i>	59
8.6.3	<i>Enhanced Restricted / Restricted Authentication Command Flow</i>	60
APPENDIX A ADDITIONAL RULES FOR AUDIO APPLICATIONS.....		61
A.1	AM824 AUDIO.....	61
A.1.1	<i>Type 1: IEC 60958 Conformant Audio</i>	61
A.1.1.1	Definition.....	61
A.1.1.2	Relationship between ASE-CCI and Embedded CCI.....	61
A.1.1.3	Usage of Mode A (EMI=11).....	61
A.1.2	<i>Type 2: DVD-Audio</i>	62
A.1.2.1	Definition.....	62
A.1.2.2	Relationship between ASE-CCI and Embedded CCI.....	62
A.1.2.3	Usage of Mode A (EMI=11).....	62
A.1.2.4	Additional rules for recording.....	62
A.1.3	<i>Type 3: Super Audio CD</i>	63
A.1.3.1	Definition.....	63
A.1.3.2	Relationship between ASE-CCI and Embedded CCI.....	63
A.1.3.3	Usage of Mode A (EMI=11).....	63
A.2	MPEG AUDIO.....	63
APPENDIX B DTCP_DESCRIPTOR FOR MPEG TRANSPORT STREAMS.....		64
B.1	DTCP_DESCRIPTOR.....	64
B.2	DTCP_DESCRIPTOR SYNTAX.....	64
B.2.1	<i>private_data_byte Definitions:</i>	65
B.3	RULES FOR THE USAGE OF THE DTCP_DESCRIPTOR.....	67
B.3.1	<i>Transmission of a partial MPEG TS</i>	67
B.3.2	<i>Transmission of a full MPEG TS</i>	67
B.3.3	<i>Treatment of the DTCP_descriptor by the sink device</i>	67
APPENDIX C LIMITATION OF THE NUMBER OF SINK DEVICES RECEIVING A CONTENT STREAM.....		68

C.1 LIMITATION MECHANISM IN SOURCE DEVICE	68
C.2 LIMITATION MECHANISM IN DTCP BUS BRIDGE DEVICE	70
C.2.1 DTCP Bus Bridge Device Source Function.....	70
C.2.2 DTCP Bus Bridge Device Sink Function.....	70
C.2.3 Extra Key handling.....	71
C.2.4 Implementation of DTCP bus bridge.....	71
C.2.4.1 Implementation of DTCP bus bridge device without Key Counter	72
C.2.4.2 Implementation of DTCP bus bridge device with Key Counter.....	72
C.2.5 Additional device certificate in a DTCP bus bridge device	73
C.2.6 Treatment of additional function in a DTCP bus bridge device.....	73
APPENDIX D DTCP ASYNCHRONOUS CONNECTION	74
D.1 PURPOSE AND SCOPE.....	74
D.2 TRANSMISSION OF PROTECTED FRAME	74
D.2.1 Overview.....	74
D.2.2 Protected Content Packet.....	74
D.2.3 Construction of Protected Frame.....	76
D.2.4 N_c Update Process.....	76
D.2.5 Duration of Exchange Keys.....	76
D.2.6 Frame Transfer type	77
D.2.6.1 File-type Transfer	77
D.2.6.2 Stream-type Transfer	77
D.3 EMBEDDED CCI	77
D.4 AKE COMMAND EXTENSIONS.....	77
D.4.1 Status Field	77
APPENDIX E CONTENT MANAGEMENT INFORMATION (CMI)	78
E.1 GENERAL	78
E.1.1 Purpose and Scope.....	78
E.1.2 General Rules for Source Devices.....	79
E.1.3 General Rules for Sink Devices	79
E.2 CMI FIELD	79
E.3 CMI DESCRIPTOR DESCRIPTIONS	80
E.3.1 CMI Descriptor General Format.....	80
E.3.2 CMI Descriptor 0	81
E.3.2.1 CMI Descriptor 0 Format.....	81
E.3.2.2 Rules for Source Devices.....	81
E.3.2.3 Rules for Sink Devices	81
E.3.3 CMI Descriptor 1	82
E.3.3.1 CMI Descriptor 1 Format.....	82
E.3.3.2 Rules for Source Devices.....	83
E.3.3.3 Rules for Sink Devices	83
E.3.4 CMI Descriptor 2	83
E.3.4.1 CMI Descriptor 2 Format.....	83
E.3.4.2 Rules for Sources Devices	83
E.3.4.3 Rules for Sink Devices	83

Figures

FIGURE 1 CONTENT PROTECTION OVERVIEW	10
FIGURE 2 STATE MACHINE EXAMPLE	13
FIGURE 3 8 BIT DIAGRAMS.....	14
FIGURE 4 PACKET FORMAT	14
FIGURE 5 CONTENT SOURCE DEVICE STATE MACHINE.....	17
FIGURE 6 CONTENT SINK DEVICE STATE MACHINE	18
FIGURE 7 BASELINE DEVICE CERTIFICATE FORMAT	21
FIGURE 8 EXTENDED DEVICE CERTIFICATE FIELDS	22
FIGURE 9 FULL AUTHENTICATION PROTOCOL FLOW OVERVIEW	26
FIGURE 10 RESTRICTED AUTHENTICATION DEVICE CERTIFICATE FORMAT	29
FIGURE 11 KEY SELECTION VECTOR	29
FIGURE 12 RESTRICTED AUTHENTICATION PROTOCOL FLOW OVERVIEW	30
FIGURE 13 CONTENT CHANNEL ESTABLISHMENT AND MANAGEMENT PROTOCOL FLOW OVERVIEW	37
FIGURE 14 ODD/EVEN BIT LOCATION IN THE PACKET HEADER	38
FIGURE 15 EMI LOCATION	39
FIGURE 16 STRUCTURE OF THE FIRST GENERATION SYSTEM RENEWABILITY MESSAGE.....	48
FIGURE 17 FORMAT OF THE CRL ENTRY TYPE BLOCK.....	49
FIGURE 18 EXAMPLE CRL.....	49
FIGURE 19 SRM EXTENSIBILITY	50
FIGURE 20 SECURITY COMMAND	52
FIGURE 21 SECURITY COMMAND CATEGORY FIELD	52
FIGURE 22 AKE CONTROL COMMAND.....	53
FIGURE 23 AKE CONTROL COMMAND STATUS FIELD.....	54
FIGURE 24 AKE CONTROL COMMAND STATUS FIELD TEST VALUES	54
FIGURE 25 AKE STATUS COMMAND	55
FIGURE 26 AKE STATUS COMMAND STATUS FIELD	55
FIGURE 27 AKE STATUS COMMAND STATUS FIELD TEST VALUES	55
FIGURE 28 AKE_ID DEPENDENT FIELD.....	56
FIGURE 29 FULL AUTHENTICATION COMMAND FLOW.....	59
FIGURE 30 ENHANCED RESTRICTED/RESTRICTED AUTHENTICATION COMMAND FLOW	60
FIGURE 31 SINK COUNTER ALGORITHM (INFORMATIVE).....	69
FIGURE 32 DTCP BUS BRIDGE STATE MACHINE WITHOUT KEY COUNTER (INFORMATIVE)	72
FIGURE 33 DTCP BUS BRIDGE STATE MACHINE WITH KEY COUNTER (INFORMATIVE).....	73
FIGURE 34 STRUCTURE OF PROTECTED CONTENT PACKET.....	74
FIGURE 35 STRUCTURE OF DATA PACKET	75
FIGURE 36 GENERIC CONSTRUCTION OF PROTECTED CONTENT PACKET IN THE PROTECTED FRAME	76

Tables

TABLE 1 LENGTH OF KEYS AND VARIABLES GENERATED BY THE DEVICE (FULL AUTHENTICATION).....	20
TABLE 2 LENGTH OF KEYS AND CONSTANTS CREATED BY DTLA (RESTRICTED AUTHENTICATION)	28
TABLE 3 LENGTH OF KEYS AND VARIABLES GENERATED BY THE DEVICE (RESTRICTED AUTHENTICATION)	28
TABLE 4 SIZE OF M6 RELATED CONTENT MANAGEMENT KEYS AND CONSTANTS	32
TABLE 5 LENGTH OF KEYS AND CONSTANTS (CONTENT CHANNEL MANAGEMENT).....	33
TABLE 6 SIZE OF M6 RELATED CONTENT MANAGEMENT KEYS AND CONSTANTS	34
TABLE 7 LENGTH OF KEYS AND CONSTANTS (CONTENT CHANNEL MANAGEMENT).....	35
TABLE 8 EMI ENCODING.....	40
TABLE 9 RELATIONSHIP BETWEEN EMI AND EMBEDDED CCI	40
TABLE 10 FORMAT-COGNIZANT SOURCE FUNCTION CCI HANDLING	41
TABLE 11 FORMAT-NON-COGNIZANT SOURCE FUNCTION CCI HANDLING	41

TABLE 12 FORMAT-COGNIZANT RECORDING FUNCTION CCI HANDLING	42
TABLE 13 FORMAT-COGNIZANT SINK FUNCTION CCI HANDLING	42
TABLE 14 FORMAT-NON-COGNIZANT RECORDING FUNCTION CCI HANDLING	42
TABLE 15 EMBEDDED CCI VALUES	43
TABLE 16 AUDIO-FORMAT-COGNIZANT SOURCE FUNCTION CCI HANDLING	43
TABLE 17 AUDIO-FORMAT-COGNIZANT RECORDING FUNCTION CCI HANDLING	44
TABLE 18 AUDIO-FORMAT-COGNIZANT SINK FUNCTION CCI HANDLING	44
TABLE 19 M6 CONTENT ENCRYPTION FORMATS.....	46
TABLE 20 AES-128 CONTENT ENCRYPTION FORMATS.....	46
TABLE 21 DV FORMAT MOVE FUNCTION MODES.....	47
TABLE 22 DV FORMAT RETENTION FUNCTION MODES	47
TABLE 23 AKE SUBFUNCTIONS.....	56
TABLE 24 AKE_PROCEDURE VALUES	57
TABLE 25 AUTHENTICATION SELECTION.....	57
TABLE 26 EXCHANGE_KEY VALUES	58
TABLE 27 RELATIONSHIPS BETWEEN SCMS STATE AND EMBEDDED CCI.....	61
TABLE 28 DVD AUDIO, RELATIONSHIP BETWEEN ASE-CCI AND EMBEDDED CCI	62
TABLE 29 SUPER AUDIO CD, RELATIONSHIP BETWEEN ASE-CCI AND EMBEDDED CCI	63
TABLE 30 DTCP_DESCRIPTOR SYNTAX.....	64
TABLE 31 SYNTAX OF PRIVATE_DATA_BYTE FOR DTCP_DESCRIPTOR	64
TABLE 32 MOVE FUNCTION MODES.....	65
TABLE 33 RETENTION FUNCTION MODES	65
TABLE 34 RETENTION STATES.....	65
TABLE 35 EPN.....	65
TABLE 36 DTCP_CCI.....	66
TABLE 37 DOT	66
TABLE 38 AST	66
TABLE 39 IMAGE_CONSTRAINT_TOKEN.....	66
TABLE 40 APS	66
TABLE 41 CONTENT TYPE	75
TABLE 42 C_T FIELD	81

Chapter 1 Introduction

1.1 Purpose and Scope

The Digital Transmission Content Protection Specification defines a cryptographic protocol for protecting audio/video entertainment content from unauthorized copying, intercepting, and tampering as it traverses digital transmission mechanisms such as a high-performance serial bus that conforms to the IEEE 1394-1995 standard. Only legitimate entertainment content delivered to a source device via another approved copy protection system (such as the DVD Content Scrambling System) will be protected by this copy protection system.

The use of this specification and access to the intellectual property and cryptographic materials required to implement it will be the subject of a license. The Digital Transmission Licensing Administrator (DTLA) is responsible for establishing and administering the content protection system described in this specification.

While DTCP has been designed for use by devices attached to serial buses as defined by the IEEE 1394-1995 standard, the developers anticipate that it will be appropriate for use with future extensions to this standard, other transmission systems, and other types of content as authorized by the DTLA.

1.2 Overview

This specification addresses four layers of copy protection:

Copy control information (CCI)

Content owners need a way to specify how their content can be used ("copy-one-generation," "copy-never," etc.). This content protection system is capable of securely communicating copy control information (CCI) between devices in two ways:

- The Encryption Mode Indicator (EMI) provides easily accessible yet secure transmission of CCI via the most significant two bits of the **sy** field of the isochronous packet header.
- CCI is embedded in the content stream (e.g. MPEG). This form of CCI is processed only by devices which recognize the specific content format.

Device authentication and key exchange (AKE)

Before sharing valuable information, a connected device must first verify that another connected device is authentic. To balance the protection requirements of the content industries with the real-world requirements of PC and consumer electronics (CE) device users, this specification includes two authentication levels, Full and Restricted.

- Full Authentication can be used with all content protected by the system.
- Restricted Authentication enables the protection of "copy-one-generation" and "no-more-copies" content only. Copying devices such as digital VCRs employ this kind of authentication.

Content encryption

Devices include a channel cipher subsystem that encrypts and decrypts copyrighted content. To ensure interoperability, all devices must support the specific cipher specified as the baseline cipher. The subsystem can also support additional ciphers, whose use is negotiated during authentication.

System renewability

Devices that support Full Authentication can receive and process system renewability messages (SRMs) created by the DTLA and distributed with content and new devices. System renewability ensures long-term integrity of the system through the revocation of compromised devices.

Figure 1 gives an overview of content protection. In this overview, the source device has been instructed to transmit a copy protection stream of content. In this and subsequent diagrams, a source device is one that can send a stream of content. A sink device is one that can receive a stream of content. Multifunction devices such as PCs and record/playback devices such as digital VCRs can be both source and sink devices.

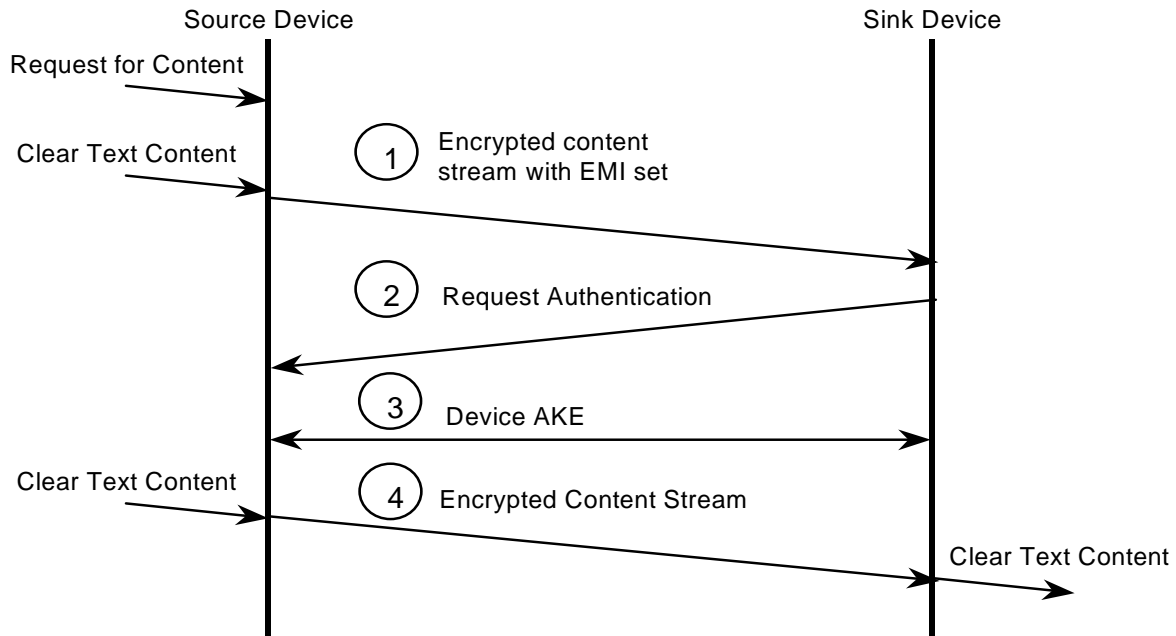

Figure 1 Content Protection Overview

1. The source device initiates the transmission of a stream of encrypted content marked with the appropriate copy protection status (e.g., "copy-one-generation," "copy-never," or "no-more-copies") via the EMI bits.¹
2. Upon receiving the content stream, the sink device inspects the EMI bits to determine the copy protection status of the content. If the content is marked "copy-never," the sink device requests that the source device initiate Full AKE. If the content is marked "copy-one-generation" or "no-more-copies" the sink device will request Full AKE, if supported, or Restricted AKE. If the sink device has already performed the appropriate authentication, it can immediately proceed to Step 4.
3. When the source device receives the authentication request, it proceeds with the type of authentication requested by the sink device, unless Full AKE is requested but the source device can only support Restricted AKE, in which case Restricted AKE is performed.
4. Once the devices have completed the required AKE procedure, a content channel encryption key can be exchanged between them. This key is used to encrypt the content at the source device and decrypt the content at the sink.

¹ If content requested by a sink device is protected, the source device may choose to transmit an empty content stream until at least one device has completed the appropriate authentication procedure required to access the content stream.

1.3 References

This specification shall be used in conjunction with the following publications. When the publications are superseded by an approved revision, the revision shall apply.

1394 Trade Association, Specification for AV/C Digital Interface Command Set General Specification Version 4.1 December 11, 2001.

1394 Trade Association Document 2001003, Audio and Music Data Transmission Protocol 2.0, August 21, 2001.

1394 Trade Association Document 2001009, AV/C Compatible Asynchronous Serial Bus Connections 2.1, July 23, 2001

1394 Trade Association Document 1999037, AV/C Command for Management of Enhanced Asynchronous Serial Bus Connections 1.0, October 24, 2000

1394 Trade Association Document 2006020, BT.601 Transport Over IEEE-1394 1.1a, October 02, 2006

Advanced Encryption Standard (AES) FIPS 197 November 26, 2001

ATSC, A/70 Conditional Access System for Terrestrial Broadcast

Cable Television Laboratories, HDND Interface Specification Version 2.2

Digital Transmission Licensing Administrator, DIGITAL TRANSMISSION PROTECTION LICENSE AGREEMENT, Development and Evaluation License

ETSI EN 300 468, DVB, Specification for Service Information (SI) in DVB Systems

IEC 61834 Helical-scan digital video cassette recording system using 6.35 mm magnetic tape for consumer use (525-60, 625-50, 1125-60 and 1250-50 systems)

IEC/ISO 13818-1:2000(E) Information Technology – Generic coding of moving pictures and associated audio information Systems, Second edition, 2000-12-01

IEEE 1363-2000, IEEE Standard Specification for Public-Key Cryptography

IEEE 1394-1995, Standard for a High Performance Serial Bus

ISO/IEC 61883, Digital Interface for Consumer Audio/Video Equipment

ITU-R Rec. BO.1516 System B Transport Stream

National Institute of Standards and Technology (NIST), Secure Hash Standard (SHS), FIPS Publication 180-2 August 1, 2002

NIST Special Publication 800-38A 2001 Edition (SP800-38A), Recommendation for Block Cipher Modes of Operation

Toshiba Corporation, Scheme for Computing Montgomery Division and Montgomery Inverse Realizing Fast Implementation, Japanese patent application number PH10-269060

1.4 Organization of this Document

This specification is organized as follows:

- Chapter 1 provides an overview of digital transmission content protection.
- Chapter 2 lists the abbreviations used throughout this document.
- Chapter 3 describes the operation of the overall Digital Transmission Content Protection System as a state machine.
- Chapter 4 addresses the particulars of the Full Authentication level of device authentication and key exchange.
- Chapter 5 addresses the particulars of the Restricted Authentication level of device authentication and key exchange.
- Chapter 6 describes the details of content channel establishment after Full or Restricted Authentication takes place.
- Chapter 7 describes the System Renewability capabilities.
- Chapter 8 covers AV/C command extensions.
- Appendix A Additional Rules for Audio Application Types
- Appendix B DTCP_Descriptor for MPEG Transport Streams
- Appendix C Limitation of the Number of Sink Devices Receiving a Content Stream
- Appendix D DTCP Asynchronous Connection
- Appendix E Content Management Information
- Volume 1 Supplement A Mapping DTCP to USB
- Volume 1 Supplement B Mapping DTCP to MOST
- Volume 1 Supplement C Mapping DTCP to Bluetooth
- Volume 1 Supplement D DTCP Use of IEEE1394 Similar Transports
- Volume 1 Supplement E Mapping DTCP to IP
- Volume 1 Supplement F DTCP 1394 Additional Localization
- Volume 1 Supplement G Mapping DTCP to WirelessHD

1.5 State Machine Notation

State machines are employed throughout this document to show various states of operation. These state machines use the style shown in Figure 2.

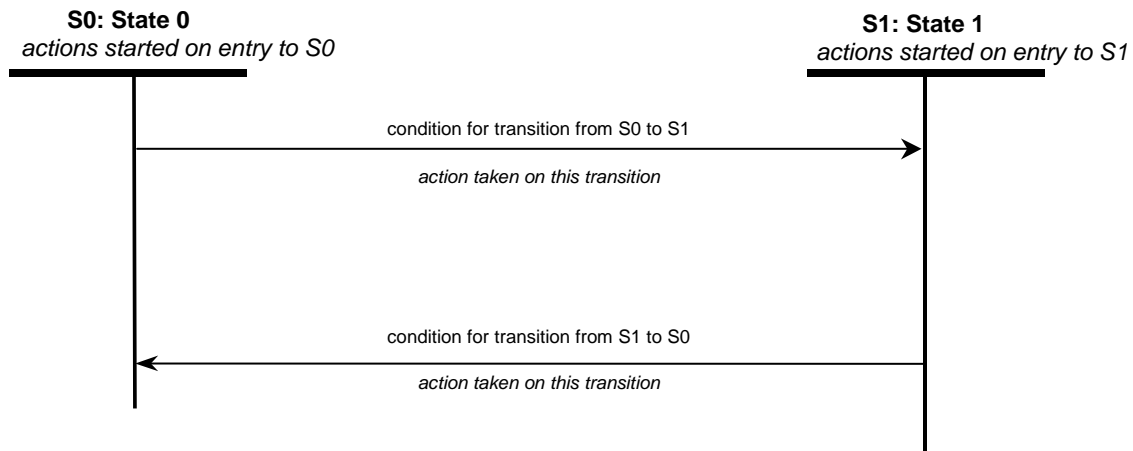

Figure 2 State Machine Example

State machines make three assumptions:

- Time elapses only within discrete states.
- State transitions are instantaneous, so the only actions taken during a transition are setting flags and variables and sending signals.
- Every time a state is entered, the actions of that state are started. A transaction that points back to the same state will restart the actions from the beginning.

1.6 Notation

The following notation will be used:

$[X]_{\text{msb}_z}$ The most significant z bits of X

$[X]_{\text{lsb}_z}$ The least significant z bits of X

$S_{X^{-1}}[M]$ Sign M using EC-DSA with private key X^{-1} (See Chapter 4)

$V_{X^1}[M]$ Verify signature of M using EC-DSA with public key X^1 (See Chapter 4)

$X || Y$ Ordered Concatenation of X with Y .

$X \oplus Y$ Bit-wise Exclusive-OR (XOR) of two strings X and Y .

1 MB = 1024 x 1024 Bytes

1.7 Numerical Values

Three different representations of number are used in this specification. Decimal numbers are represented without any special notation. Binary numbers are represented as a string of binary (0, 1) digits followed by a subscript 2 (e.g., 1010_2). Hexadecimal numbers are represented as a string of hexadecimal digits (0..9,A..F) followed by a subscript 16 (e.g., $3C2_{16}$).

1.8 Byte Bit Ordering

Data is depicted from most significant to least significant when scanning document from top to bottom and left to right.

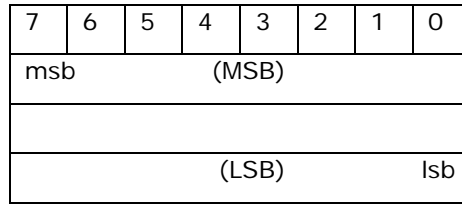
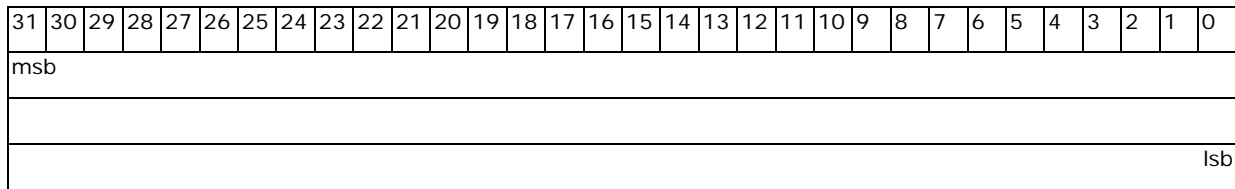

Figure 3 8 Bit diagrams



1.9 Packet Format

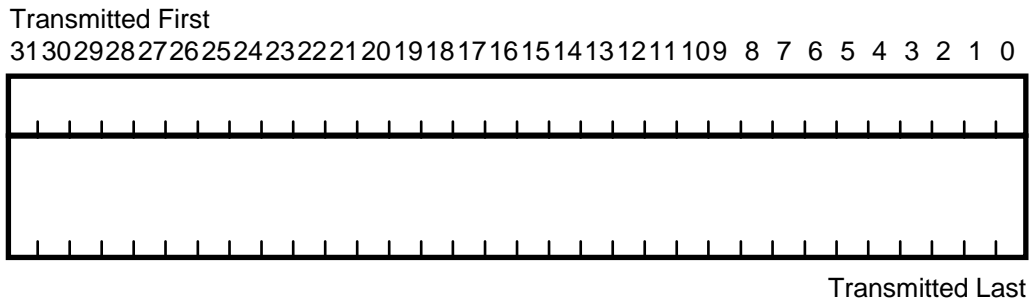

Figure 4 Packet Format

1.10 Treatment of Portions of the Specification marked “NOT ESTABLISHED”

Features of this specification that are labeled as “NOT ESTABLISHED” describe capabilities the usage of which has not yet been implemented or established by the 5C.

Chapter 2 Abbreviations

This chapter lists abbreviations and acronyms used throughout this document.

2.1 Alphabetical List of Abbreviations and Acronyms

Advanced Encryption Standard (AES)

Advanced Television Systems Committee (ATSC)

Analog Protection System (APS)

Application Specific Embedded Copy Control Information (ASE-CCI)

Asynchronous Connection (AC)

Audio Video Control (AV/C)

Authentication and Key Exchange (AKE)

Automatic Gain Control (AGC)

Certificate Revocation List (CRL)

Copy Control Information (CCI)

Copy Generation Management System (CGMS)

Common Isochronous Packet (CIP)

Consumer Electronics (CE)

Content Management Information (CMI)

Converted Cipher-Block-Chaining (C-CBC)

Cyclic Redundancy Check (CRC)

Data Encryption Standard (DES)

Data Packet (DP)

Diffie-Hellman (DH)

Digital Signature Algorithm (DSA)

Digital Signature Standard (DSS)

Digital Transmission Content Protection (DTCP)

Digital Transmission Licensing Administrator (DTLA)

Digital Versatile Disc (DVD)

Discrete Logarithm Signature Primitive, DSA version (DLSP-DSA)

Discrete Logarithm Verification Primitive, DSA version (DLVP-DSA)

DTCP Asynchronous Connection (DTCP-AC)

Encryption Plus Non-assertion (EPN)

Elliptic Curve (EC)

Elliptic Curve Cryptography (ECC)

Elliptic Curve Digital Signature Algorithm (EC-DSA)

Elliptic Curve Digital Signature Standard (EC-DSS)

Elliptic Curve Diffie-Hellman (EC-DH)

Elliptic Curve Secret Value Derivation Primitive, Diffie-Hellman version (ECSVDP-DH)

Elliptic Curve Signature Schemes with Appendix (ECSSA)

Encoding Method for Signatures with Appendix on SHA-1 (EMSA-SHA-1)

Encryption Mode Indicator (EMI)

Federal Information Processing Standards (FIPS)

Function Control Protocol (FCP)

Home Digital Network Device (HDND)

Institute of Electrical and Electronics Engineers (IEEE)

International Electrotechnical Commission (IEC)

International Electrotechnical Commission Publicly Available Specifications (IEC-PAS)

International Organization for Standardization (ISO)

Key Selection Vector (KSV)

Least Significant Bit (lsb)

Least Significant Byte (LSB)

Menezes-Okamoto-Vanstone (MOV)

Most Significant Bit (msb)

Most Significant Byte (MSB)

Motion Picture Experts Group (MPEG)

National Institute of Standards and Technology (NIST)

Personal Computer (PC)

Program Management Table (PMT)

Protected Content Packet (PCP)

Random Number Generator (RNG)

Secure Hash Algorithm, revision 1 (SHA-1)

Secure Hash Standard (SHS)

Set Top Box (STB)

Source node ID (SID)

System Renewability Message (SRM)

Video Cassette Recorder (VCR)

Chapter 3 The Digital Transmission Content Protection System

3.1 Content Source Device

Figure 5 shows the various states of operation for a device that is a source of content.

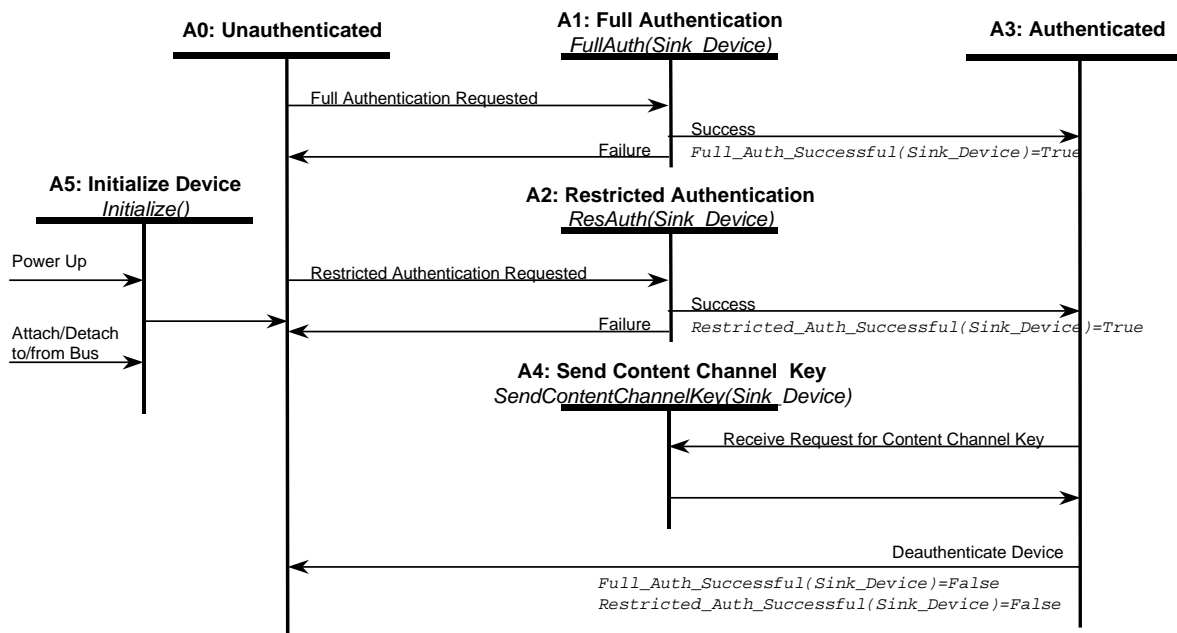

Figure 5 Content Source Device State Machine

A Power up or Attach/Detach to/from the bus event resets this state machine into **State A5: Initialize Device**.

State A5: Initialize Device. In this state, the device is initialized.

Transition A5:A0. This transition to **State A0: Unauthenticated** occurs following the completion of the initialization process.

State A0: Unauthenticated. A device is in an unauthenticated state, waiting to receive a request to perform the Full or Restricted Authentication procedure.

Transition A0:A1. This transition occurs when the device receives a request to perform the Full Authentication procedure with a sink device (*Sink_Device*).

State A1: Full Authentication. In this state, the process *FullAuth(Sink_Device)* is performed. This process is described in detail in Chapter 4.

Transition A1:A3. This transition occurs when *FullAuth(Sink_Device)* has been successfully completed.

Set *Full_Auth_Successful(Sink_Device)* = True

Transition A1:A0. This transition occurs when *FullAuth(Sink_Device)* is unsuccessful.

Transition A0:A2. This transition occurs when the device receives a request to perform the Restricted Authentication procedure with a sink device (*Sink_Device*).

State A2: Restricted Authentication. In this state, the device executes the process *ResAuth(Sink_Device)*. This procedure is described in detail in Chapter 5.

Transition A2:A3. This transition occurs when *ResAuth(Sink_Device)* has been successfully completed.

Set *Restricted_Auth_Successful(Sink_Device)* = True

Transition A2:A0. This transition occurs when *ResAuth(Sink_Device)* is unsuccessful.

State A3: Authenticated. When a device is in this state, it has successfully completed either the Full or Restricted Authentication procedure.

Transition A3:A4. An authenticated device is requested to send the values necessary to construct a Content Key to a sink device.

State A4: Send Content Channel Key. In this state, the source device sends values necessary to create a content key to an authenticated sink device by executing *SendContentChannelKey(Sink_Device)*. This process is described in Chapter 6.

Transition A4:A3. This transition occurs on completion of the process *SendContentChannelKey(Sink_Device)*.

Transition A3:A0.

Set *Full_Auth_Successful(Sink_Device)* = False

Set *Restricted_Auth_Successful(Sink_Device)* = False

3.2 Content Sink Device

Figure 6 shows the various states of operation of a device that is a sink for content.

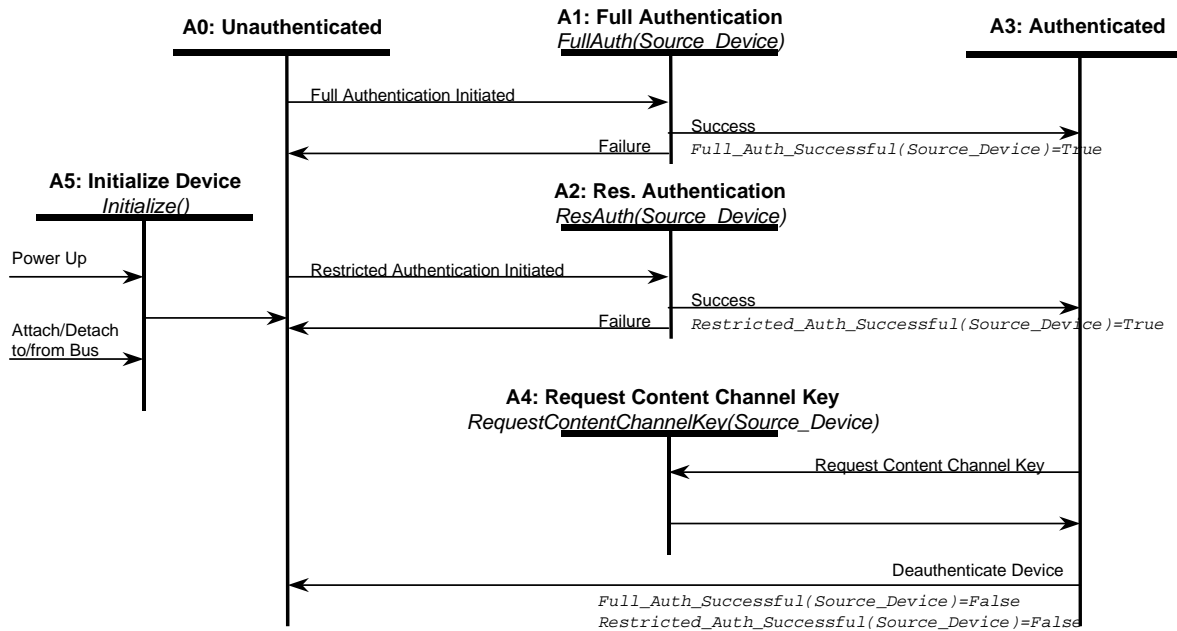

Figure 6 Content Sink Device State Machine

A Power up or Attach/Detach to/from the bus event resets this state machine into **State A5: Initialize Device**.

State A5: Initialize Device. In this state, the device is initialized.

Transition A5:A0. This transition to **State A0: Unauthenticated** occurs following the completion of the initialization process.

State A0: Unauthenticated. A device is in an unauthenticated state, waiting to initiate a request to perform the Full or Restricted Authentication procedure.

Transition A0:A1. This transition occurs when the device initiates a request to perform the Full Authentication procedure with another device(*Source_Device*).

State A1: Full Authentication. In this state, the process *FullAuth(Source_Device)* is performed. This process is described in detail in Chapter 4.

Transition A1:A3. This transition occurs when *FullAuth(Source_Device)* has been successfully completed.

Set *Full_Auth_Successful(Source_Device)* = True

Transition A1:A0. This transition occurs when *FullAuth(Source_Device)* is unsuccessful.

Transition A0:A2. This transition occurs when the device initiates a request to perform the Restricted Authentication procedure with another device(*Source_Device*).

State A2: Restricted Authentication. In this state, the device executes the process *ResAuth(Source_Device)*. This procedure is described in detail in Chapter 5.

Transition A2:A3. This transition occurs when *ResAuth(Source_Device)* has been successfully completed.

Set *Restricted_Auth_Successful(Source_Device)* = True

Transition A2:A0. This transition occurs when *ResAuth(Source_Device)* is unsuccessful.

State A3: Authenticated. When a device is in this state, it has successfully completed either the Full or Restricted Authentication procedure.

Transition A3:A4. An authenticated device needs to request a Content Key to gain access to copy protected content.

State A4: Request Content Channel Key. In this state, an authenticated sink device requests the values necessary to create a Content Key by executing the process *RequestContentChannelKey(Source_Device)*. This process is described in Chapter 6.

Transition A4:A3. This transition occurs on completion of the process *RequestContentChannelKey(Source_Device)*.

Transition A3:A0.

Set *Full_Auth_Successful(Source_Device)* = False

Set *Restricted_Auth_Successful(Source_Device)* = False

Chapter 4 Full Authentication

4.1 Introduction

This chapter addresses the particulars of the Full Authentication level of device authentication and key exchange. Full Authentication employs the public key based Elliptic Curve Digital Signature Algorithm (EC-DSA) for signing and verification. It also employs the Elliptic Curve Diffie-Hellman (EC-DH) key exchange algorithm to generate a shared authentication key.

4.2 Notation

The notation introduced in this section is used to describe the cryptographic processes. All operations in the elliptic curve domain are calculated on an elliptic curve E defined over $GF(p)$.

4.2.1 Defined by the DTLA

The following parameters, keys, constants, and certificates are generated by the DTLA.

4.2.1.1 General

E denotes the elliptic curve over the finite field $GF(p)$ of p elements represented as integers modulo p . Elliptic curve points consist of the x -coordinate and y -coordinates, respectively; for an elliptic curve point $P = (x_p, y_p)$ which is not equal to the elliptic curve point at infinity.

	Description	Size (bits)
p	A prime number greater than 3 of finite field $GF(p)$	160
a, b	The coefficients of elliptic curve polynomial	160 each
G	The basepoint for the elliptic curve E	320
r	The order of basepoint G	160
L^{-1}	DTLA private key of EC-DSA key pair which is an integer in the range $(1, r-1)$	160
L^1	DTLA public key of EC-DSA key pair where $L^1 = L^{-1}G$	320

These parameters, with the exception of L^{-1} , are in DTCP Specification available under license from DTLA.

4.2.1.2 For Device X

	Description	Size (bits)
X^1	Device private key of EC-DSA key pair which is an integer in the range $(1, r-1)$	160
X^1	Device public key of EC-DSA key pair where $X^1 = X^1G$	320

4.2.2 Notation used during Full Authentication

The following additional values are generated and used by the devices during Full Authentication:

Key or Variable	Description	Size (bits)
X_n	Nonce (random challenge generated by RNG_F)	128
X_K	Random value used in EC-DH key exchange generated by RNG_F in the device (integer in the range $[1, r-1]$)	160
X_V	EC-DH first phase value (X_KG) calculated in the device (point on the elliptic curve E)	320
X_{SRMV}	Version number of the system renewability message (SRMV) stored by the device (See Chapter 7)	16
X_{SRMC}	Indicates the number of SRM part(s) which are currently stored in the non-volatile memory of the device. A value of SRMC indicates that the first SRMC+1 generations of SRMs are currently stored by the device (See Chapter 7)	4
K_{AUTH}	Authentication key which is the least significant 96-bits of shared data created through EC-DH key exchange	96

Table 1 Length of keys and variables generated by the device (Full Authentication)

4.2.3 Device Certificate Formats

A device certificate is given to each compliant device X by the DTLA and is referred to as X_{CERT} . This certificate is stored in the compliant device and used during the authentication process.

4.2.3.1 Baseline Format

The following Figure 7 shows the baseline device certificate format:

31	30	29	28	27	26	25	24	23	22	21	20	19	18	17	16	15	14	13	12	11 ²	10	9	8	7	6	5	4	3	2	1	0
Certificate Type				Format				Dev Gen				Reserved (zero)									C2	AL	AP	Device ID							
Device ID continued (Total 40 bits)																															
Device EC-DSA Public Key (320 bits)																															
DTLA EC-DSA signature of all preceding fields (320 bits for c and followed by d value)																															

Figure 7 Baseline Device Certificate Format

Device certificates are comprised of the following Baseline Format fields:

- **Certificate Type** (4 bits). The only encoding which is currently defined is 0, which indicates the DTCP certificate. All other encodings are currently reserved.
- **Certificate Format** (4 bits). This field specifies the format for a specific type of certificate. Currently three formats are defined:
 - **Format 0** = the Restricted Authentication device certificate format (See Chapter 5).
 - **Format 1** = the Baseline Full Authentication device certificate format.
 - **Format 2** = the Extended Full Authentication device certificate format (NOT ESTABLISHED³).
 - **Other encodings are currently reserved.**
- **Device Generation** (X_{SRMG} , 4 bits). This field indicates the non-volatile memory capacity and therefore the maximum generation of renewability messages that this device supports (Described in Chapter 7). The encoding 0 indicates that the device shall have a non-volatile memory capacity for storing First-Generation SRM. The encoding 1 indicates that the device shall have a non-volatile memory capacity for storing Second-Generation SRM.
- **Reserved Field** (9 bits). These bits are reserved for future definition and are currently defined to have a value of zero.
- **C2 flag** (1 bit). The C2 flag is set to a value of one to indicate, when used in the CVP-2 authentication process⁴, that the associated device is DLNA CVP-2 certified. The C2 flag has no meaning when a DTCP CVP-2 Device Certificate is used for the DTCP authentication process.
- **AL flag** (1 bit). Additional Localization flag. The AL flag is set to value of one to indicate that the associated device is capable of performing the additional localization test, otherwise shall be set to value of zero.
- **AP flag** (1 bit). Authentication Proxy flag. A device certificate with an AP flag value of one is used by a DTCP bus bridge device, which receives a content stream using a sink function and retransmits that stream to another bus using a source function⁵. The procedures for processing this field are specified in Appendix C.
- The **device's ID** number (X_{ID} , 40 bits) assigned by the DTLA.
- The **EC-DSA public key** of the device (X^1 , 320 bits)
- An **EC-DSA signature** from the DTLA of the components listed above (320 bits)

The overall size of a Baseline Format device certificate is 88 bytes.

² Bit 11 is reserved for a specification under development.

³ See section 1.10

⁴ See the DTLA CVP-2 Volume 1 Specification

⁵ To maintain consistency with the previous version of this specification, the value of AP flag for a device with a common device certificate is set to one regardless of the DTCP bus bridge capability.

4.2.3.2 Extended Format Fields (NOT ESTABLISHED³ Components of the Device Certificate)

In addition to the Baseline Format fields, each device certificate may optionally include the following Extended Format fields²:

A **device capability mask** indicating the properties of the device and channel ciphers supported. (X_{Cap_Mask} , 32 bits)

An **EC-DSA signature** from the DTLA of all preceding components in the device certificate. (320 bits)

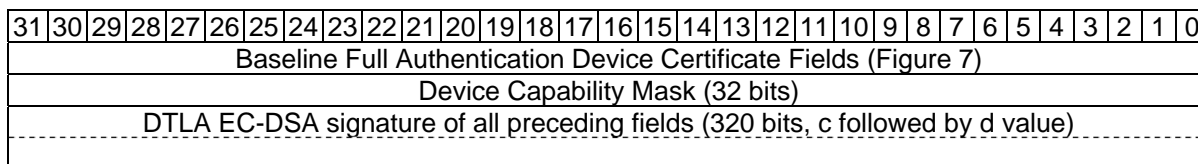

Figure 8 Extended Device Certificate Fields

Device Capability Mask

The device capability mask is provided to describe the extensibility features supported by a given device.

- **bit[0]** denotes AES-128 capability when $b[0]=1$ the device has optional cipher AES-128 capability and when $b[0]=0$ then it does not.
- **bit[31..1]** are reserved.

Devices that do not support the device capability mask are assumed to only support the baseline cryptographic features defined by this content protection system (e.g., the 56-bit M6 Baseline Cipher).

4.3 Manufacture of Compliant Devices

All compliant devices that support Full Authentication (that is, each item manufactured, regardless of brand and model) will be assigned a unique Device ID (X_{ID}) and device EC-DSA public/private key pair (X^T, X^{-T}) generated by the DTLA. X^{-T} must be stored within the device in such a way as to prevent its disclosure. Compliant devices must also be given a device certificate (X_{CERT}) by the DTLA. This certificate is stored in the compliant device and used during the authentication process. In addition, the compliant device will need to store the other constants and keys necessary to implement the cryptographic protocols.

4.4 Cryptographic Functions

4.4.1 SHA-1 (Secure Hash Algorithm, revision 1)

SHA-1, as described in FIPS PUB 180-2⁶ is the algorithm used in DSS to generate a message digest of length 160 bits. A message digest is a value calculated from message. It is similar in concept to a checksum, but computationally infeasible to forge.

4.4.2 Random Number Generator

A high quality random number generator is required for Full Authentication. The output of this random number generator is indicated by the function RNG_F that is described in DTCP Specification available under license from DTLA.

4.4.3 Elliptic Curve Cryptography (ECC)

These cryptographic algorithms are based upon cryptographic schemes, primitives, and encoding methods described in IEEE 1363-2000.

An Elliptic Curve Cryptosystem (ECC) is used as the cryptographic basis for DH and DSA.

The definition field classifies ECC implementations. For this system, the definition field used is $GF(p)$ where p is a large prime number greater than three. An elliptic curve E over the field $GF(p)$, where $p > 3$, is defined by the parameters a and b and the set of solutions (x, y) to the elliptic curve equation together with an extra point often called the point at infinity. The point at infinity is the identity element of the abelian group, $(E, +)$. The elliptic curve equation used is

$$y^2 = x^3 + ax + b \text{ where } 4a^3 + 27b^2 \neq 0,$$

Where a, b, x, y , are elements of $GF(p)$. A point P on the elliptic curve consists of the x-coordinate and the y-coordinate of a solution to this equation, or the point at infinity, and is designated $P = (x_p, y_p)$.

For EC-DSA and EC-DH, a basepoint G on the elliptic curve is selected. All operations in the elliptic curve domain are calculated on an elliptic curve E defined over $GF(p)$. The public key Y^1 (a point on the elliptic curve) and private key Y^{-1} (a scalar value satisfying $0 < Y^{-1} < r$) for each entity satisfies the equation:

$$Y^1 = Y^{-1} G$$

In specifying the elliptic curve used:

The order of basepoint G will have a large prime factor.

The system will be robust against MOV reduction attack, since super singular elliptic curves are avoided.

⁶ National Institute of Standards and Technology (NIST), "Secure Hash Standard (SHS)," FIPS Publication 180-2, August 1, 2002.

4.4.3.1 Elliptic Curve Digital Signature Algorithm (EC-DSA)

Signature

The following signature algorithm is based on the ECSSA digital signature scheme using the DLSP-DSA signature primitive and EMSA-SHA-1 encoding method defined in of IEEE 1363-2000.

Input:

- M = the data to be signed
- X^{-1} = the private key of the signing device (must be kept secret)
- $p, a, b, G,$ and r = the elliptic curve parameters associated with X^{-1}

Output:

- $S_{X^{-1}}[M]$ = a 320-bit signature of the data, M , based on the private key, X^{-1}

Algorithm:

- Step 1,** Generate a random value, u , satisfying $0 < u < r$, using RNG_F . A new value for u is generated for every signature and shall be unpredictable to an adversary for every signature computation. Also, calculate the elliptic curve point, $V = uG$.
- Step 2,** Calculate $c = x_V \bmod r$ (the x-coordinate of V reduced modulo r). If $c = 0$, then go to **Step 1**.
- Step 3,** Calculate $f = [SHA-1(M)]_{\text{msb_bits_in_r}}$. That is, calculate the SHA-1 hash of M and then take the most significant bits of the message digest that is the same number of bits as the size of r .
- Step 4,** Calculate $d = [u^{-1}(f + cX^{-1})] \bmod r$ (note that u^{-1} is the modular inverse of $u \bmod r$ while X^{-1} is the private key of the signing device). If $d = 0$, then go to **Step 1**.
- Step 5,** Set first 160 bits of $S_{X^{-1}}[M]$ equal to the big endian representation of c , and the second 160 bits of $S_{X^{-1}}[M]$ equal to the big endian representation of d . ($S_{X^{-1}}[M] = c || d$)

Verification

The following verification algorithm is based on the ECSSA digital signature scheme using the DLVP-DSA signature primitive and EMSA-SHA-1 encoding method defined in of IEEE 1363-2000.

Input:

- $S_{X^{-1}}[M]$ = an alleged 320-bit signature ($c || d$) of the data, M , based on the private key, X^{-1}
- M = the data associated with the signature
- X^1 = the public key of the signing device
- $p, a, b, G,$ and r = the elliptic curve parameters associated with X^{-1}

Output:

- "valid" or "invalid", indicating whether the alleged signature is determined to be valid or invalid, respectively

Algorithm:

- Step 1,** Set c equal to the first 160 bits of $S_{X^{-1}}[M]$ interpreted as in big endian representation, and d equal to the second 160 bits of $S_{X^{-1}}[M]$ interpreted as in big endian representation. If c is not in the range $[1, r - 1]$ or d is not in the range $[1, r - 1]$, then output "invalid" and stop.
- Step 2,** Calculate $f = [SHA-1(M)]_{\text{msb_bits_in_r}}$. That is, calculate the SHA-1 hash of M and then take the most significant bits of the message digest that is the same number of bits as the size of r .
- Step 3,** Calculate $h = d^{-1} \bmod r$, $h_1 = (fh) \bmod r$, and $h_2 = (ch) \bmod r$.
- Step 4,** Calculate the elliptic curve point $P = (x_p, y_p) = h_1G + h_2X^1$. If P equals the elliptic curve point at infinity, then output "invalid" and stop.
- Step 5,** Calculate $c' = x_p \bmod r$. If $c' = c$, then output "valid"; otherwise, output "invalid."

4.4.3.2 Elliptic Curve Diffie-Hellman (EC-DH)

The following shared secret derivation algorithm is based on the ECSVDP-DH primitive defined in IEEE 1363-2000.

Input:

- Y_V = the Diffie-Hellman first phase value generated by the other device (an elliptic curve point)
- $p, a, b, G,$ and r = the elliptic curve parameters associated with X^{-1}

Output:

- X_V = the Diffie-Hellman first phase value (an elliptic curve point)
- the x-coordinate of $X_K Y_V$ = the shared secret generated by this algorithm (must be kept secret from third parties)

Algorithm:

Step 1, Generate a random integer, X_K , in the range $[1, r-1]$ using RNG_F . A new value for X_K is generated for every shared secret and shall be unpredictable to an adversary. Also, calculate the elliptic curve point, $X_V = X_K G$.

Step 2, Output X_V .

Step 3, Calculate $X_K Y_V$. Output the x-coordinate of $X_K Y_V$ as the secret shared.

4.4.3.3 Implementation of the Elliptic Curve Cryptosystem

A range of implementations of the Elliptic Curve Cryptosystem can be realized which are compatible with the IEEE 1363 primitives described in this section.

Efficient implementations of an elliptic curve cryptosystem can be realized by performing computations within the Montgomery space using new definitions of the basic arithmetic operations of addition, subtraction, multiplication, and inverse⁷.

⁷ Japanese patent application number: PH10-269060.

4.5 Protocol Flow

4.5.1 Protocol Flow Overview

The following Figure 9 gives an overview of the Full Authentication protocol flow.

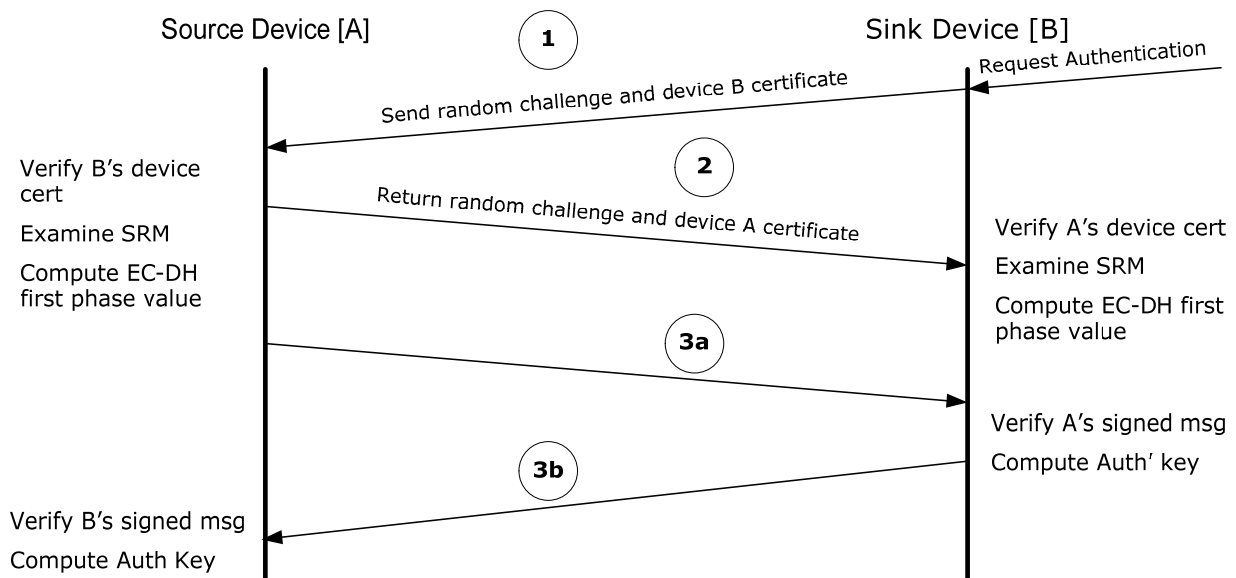

Figure 9 Full Authentication Protocol Flow Overview

During Full Authentication:

1. The sink device requests authentication by sending a random challenge and its device certificate. This can be the result of the sink device attempting to access a protected content stream (whose EMI is set to "Copy-never," "No-more-copies," or "Copy-one-generation"). The sink device may request authentication on a speculative basis, before attempting to access a content stream. If a sink device attempts speculative authentication, the request can be rejected by the source.
2. Device A then returns a random challenge and its device certificate. If the value of the other device's certificate type or format fields is reserved, the authentication should be immediately aborted. After the random challenge and device certificate exchange, each device verifies the integrity of the other device's certificate using EC-DSA. If the DTLA signature is determined to be valid, the devices examine the certificate revocation list embedded in their system renewability messages (see Chapter 7) to verify that the other device has not been revoked. If the other device has not been revoked, each device calculates a EC-DH key exchange first-phase value (See section 4.4.3.2).
3. The devices then exchange messages containing the EC-DH key exchange first-phase value, the Renewability Message Version Number and Generation of the system renewability message stored by the device, and a message signature containing the other device's random challenge concatenated to the preceding components. The devices verify the signed messages received by checking the message signature using EC-DSA with the other device's public key. This verifies that the message has not been tampered with. If the signature cannot be verified, the device refuses to continue. In addition, by comparing the exchanged version numbers, devices can at a later time invoke the system renewability mechanisms (See Section 7.2 for the details of this procedure).

Each device calculates an authentication key by completing the EC-DH key exchange.

A detailed description of the Full Authentication protocol and associated state machine can be found in the DTCP Specification available under license from DTLA.

Chapter 5 Restricted Authentication

5.1 Introduction

This chapter describes the authentication and key exchange between source and sink devices that employ asymmetric key management and common key cryptography for “Copy-one-generation” and “No-more-copy” contents. These kinds of devices, which typically have limited computation resources, follow a Restricted Authentication protocol instead of Full Authentication. Restricted Authentication relies on the use of shared secrets and hash function to respond to a random challenge.

The Restricted Authentication method is based on a device being able to prove that it holds a secret shared with other devices. One device authenticates another by issuing a random challenge that is responded to by modifying it with the shared secret and hashing.

5.2 Notation

The notation introduced in this section is used to describe the cryptographic process and protocol used for Restricted Authentication.

5.2.1 Defined by the DTLA

The following parameters, keys, constants, and certificates must be generated by the DTLA.

5.2.1.1 General

The parameters defined in Section 4.2.1 are also used during Restricted Authentication by Source devices that also support Full Authentication.

5.2.1.2 For Device X

A device certificate (X_{CERT}) given to compliant device X by the DTLA and used during the authentication process (See the Section 5.2.3 for details).

	Description	Size (bits)
“Copy-one-generation” Sink Device Keys ($X_{Kcosnk1} \dots X_{Kcosnk12}$)	Each device which is a sink of “Copy-one-generation” content receives 12 64 bit keys from the DTLA.	64 (Each)
“Copy-one-generation” Source Device Keys ($X_{Kcosrc1} \dots X_{Kcosrc12}$)	Each device which is a source of “Copy-one-generation” content receives 12 64 bit keys from the DTLA.	64 (Each)
“No-more-copies” Sink Device Keys ($X_{Knmsnk1} \dots X_{Knmsnk12}$)	Each device which is a sink of “No-more-copies” content receives 12 64 bit keys from the DTLA.	64 (Each)
“No-more-copies” Source Device Keys ($X_{Knmsrc1} \dots X_{Knmsrc12}$)	Each device which is a source of “No-more-copies” content receives 12 64 bit keys from the DTLA.	64 (Each)
Key Selection Vector (X_{Ksv})	This key selection vector (KSV) determines which keys will be used during the Restricted Authentication procedure with this device. Only one KSV is required for devices that can be both a source and sink of content.	12

Table 2 Length of Keys and Constants created by DTLA (Restricted Authentication)

Devices contain the keys appropriate to the type of content and functions that they perform.

5.2.2 Notation used during Restricted Authentication

The following additional values are generated and used by the devices during Restricted Authentication:

	Description	Size (bits)
(A_n, B_n)	Nonce (random challenge generated by RNG_R)	64
(K_v, K'_v)	Verification Keys	64
(R, R')	Responses	64
(K_{AUTH}, K'_{AUTH})	Authentication Keys	96

Table 3 Length of keys and variables generated by the device (Restricted Authentication)

5.2.3 Device Certificate Format

A Restricted Authentication Device Certificate is used in the Restricted Authentication process. Each Restricted Authentication device certificate is assigned by the DTLA and includes a Device ID and a signature generated by the DTLA. All compliant sink devices that support only Restricted Authentication shall have this certificate. Figure 10 shows this device certificate format.

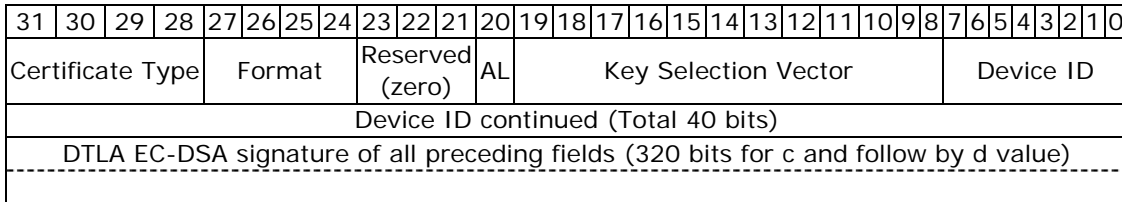

Figure 10 Restricted Authentication Device Certificate Format

The Restricted Authentication device certificate is comprised of the following fields:

- **Certificate Type** (4 bits). (See Section 4.2.3.1 for a description of the encoding)
- **Certificate Format** (4 bits). (See Section 4.2.3.1 for a description of the encoding)
- **Reserved Field** (3 bits). These bits are reserved for future definition and are currently defined to have a value of zero.
- **AL flag** (1 bit). Additional Localization flag. The AL flag is set to value of one to indicate that the associated device is capable of performing the additional localization test, otherwise shall be set to value of zero.
- **Key Selection Vector** (X_{KSV} , 12 bits) assigned by the DTLA. This vector determines which keys will be used during the Restricted Authentication procedure with this device. This KSV is used regardless of the EMI of the stream to be handled or whether the device is being used as a source or sink of content. The encoding of this field is as follows:

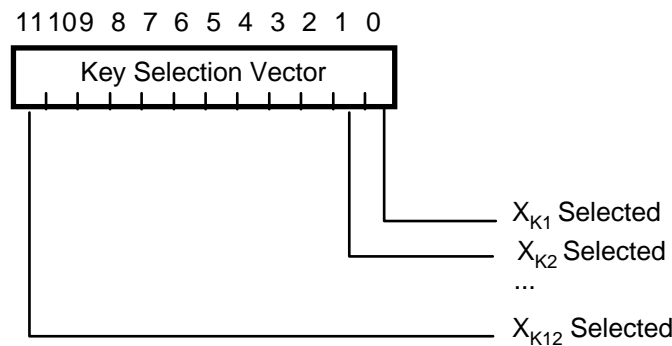

Figure 11 Key Selection Vector

- The **Device ID** number (X_{ID} , 40 bits) assigned by the DTLA.
- A **EC-DSA signature** from the DTLA of the components listed above (320 bits)

The overall size of a Restricted Authentication device certificate format is 48 bytes.

5.2.4 Random Number Generator

A random number generator is required for Restricted Authentication. The output of this random number generator is indicated by the function RNG_R . Either RNG_R or RNG_F as described in DTCP Specification available under license from DTLA.

5.3 Protocol Flow

5.3.1 Protocol Flow Overview

Figure 12 gives an overview of the Restricted Authentication protocol flow.

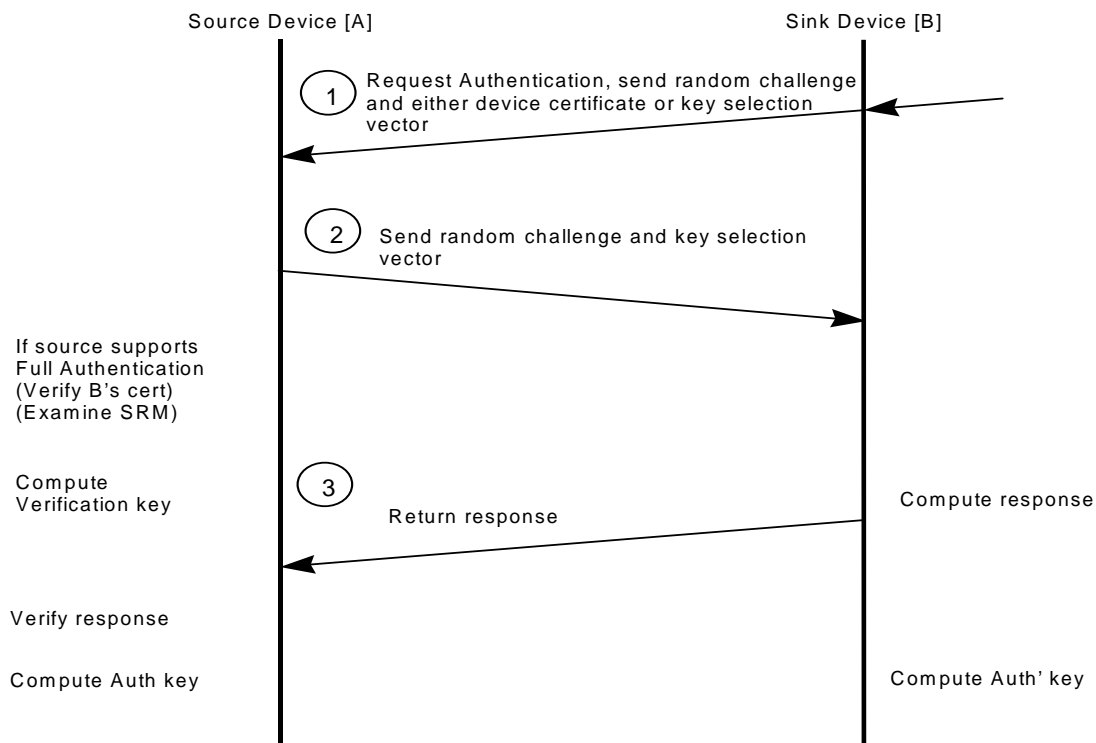

Figure 12 Restricted Authentication Protocol Flow Overview

During Restricted Authentication:

1. The sink device initiates the authentication protocol by sending an asynchronous challenge request to the source device. This request contains the type of Exchange Key to be shared by the source and sink devices as well as a random number generated by the sink device. If the sink device knows that the source device does not have a capability for Full Authentication, the sink sends its KSV to the source; otherwise, the sink sends its Restricted Authentication device certificate.
2. The source device generates a random challenge and sends it to the sink device. If the source device supports Full Authentication, it extracts the Device ID of the sink device from the certificate sent by the sink. It then checks 1) that the certificate sent by the sink is valid and 2) that the sink's Device ID is not listed in the certification revocation list in the system renewability message stored in the source device. Also, if the value of the other device's certificate type or format fields is reserved, the authentication should be immediately aborted.

If these checks are completed successfully, the source continues the protocol by computing the verification key.

3. After receiving a random challenge back from the source device, the sink device computes a response using a verification key that it has computed and sends it to the source.

After the sink device returns a response, the source device compares this response with similar information generated at the source side using its verification key. If the comparison matches its own calculation, the sink device has been verified and authenticated. If the comparison does not match it, the source device shall reject the sink device. Finally, each device computes the authentication key.

A detailed description of the Restricted Authentication protocol and associated state machine can be found in the DTCP Specification available under license from DTLA.

Chapter 6 Content Channel Management and Protection

6.1 Introduction

This chapter details the mechanisms used to 1) share an Exchange Key between a source device and a sink device and 2) establish and manage the encrypted isochronous channel through which protected content flows. Either Full or Restricted Authentication (depending on the capabilities of the device) shall be completed prior to establishing a content channel.

6.2 Content Management Keys

6.2.1 Exchange Key (K_X) and Session Exchange Key (K_S)

Either Exchange Key (K_X) or Session Exchange Key (K_S) is used to calculate a content key (K_C) to encrypt content. Note that K_X and K_S are collectively described as the "Exchange Key" if " (K_X) " or " (K_S) " is not accompanied.

6.2.1.1 Exchange Keys (K_X)

A common set of Exchange Keys (K_X) are established between a source device and all sink devices that have completed the appropriate authentication procedure (either Full or Restricted) with the source device required to handle content with a specific EMI value (Section 6.4.2).

A single exchange key shall be used for all EMI values for an optional content cipher.

The procedure for establishing an Exchange Key (K_X) is described in Section 6.3.1.

6.2.1.2 Session Exchange Keys (K_S)

Session Exchange Keys (K_S) are unique for each connected sink device while the Exchange Key (K_X) is common to all connected sink devices. Support of the Session Exchange Key is not mandated and the Session Exchange Key is established when both a source device and a sink device support Session Exchange Key. Session Exchange Key can be used for the transmission of content which shall not be sent to multiple sink devices. Session Exchange Key can also be used for the transmission of content which can be sent using Exchange Key (K_X).

The following rules shall be applied to Session Exchange Key.

- A single Session Exchange Key shall be used for all EMI values.
- Source devices shall provide Session Exchange Key only with the Full authentication procedure.
- Source devices must ensure that all of the values of the Session Exchange Keys (K_S) and Exchange Keys (K_X) are different.
- Source devices must ensure that the Session Exchange Key used for each authenticated sink device is unique.
 - Source devices may send the same value of the available Session Exchange Key to a sink device with the same value of Device ID and AP flag value of zero in the sink's device certificate.
 - Source devices may send the same value of the available Session Exchange Key to sink device with a common device certificate by using ID_U [along with](#) instead of Device ID.
 - Source devices shall not send the same value of the available Session Exchange Key to a sink device with AP flag value of one in the sink's device certificate unless the source device can uniquely identify the sink device by using ID_U [along with Device ID](#).
- Source devices during content transmission may swap the active exchange key as desired between the Exchange Key (K_X) or Session Exchange Key (K_S).

In addition to the above rules, the same rules as Exchange Keys (K_X) shall be independently applied to each Exchange Keys (K_S) unless otherwise noted.

6.2.2 Content Key (K_C)

6.2.2.1 K_C For M6

The **Content Key** (K_C) is used as the key for the content encryption engine. K_C is computed from the three values shown below:

- An Exchange Key (K_X) assigned to each EMI used to protect the content. Note that K_S is used instead of K_X in the following formulas when Session Exchange Key is used.
- A random number N_C generated by the source device (using RNG_F for devices that support Full Authentication and RNG_R for devices that support only Restricted Authentication) which is sent in plain text to all sink devices in asynchronous packet(s).
- Constant value C_a , C_b , or C_c , which corresponds to an encryption mode EMI in the packet header.

The Content Key is generated as follows:

$$K_C = J[K_X, f[EMI], N_C] \text{ where:}$$

$$f[EMI] = C_a \text{ when EMI is mode A}$$

$$f[EMI] = C_b \text{ when EMI is mode B}$$

$$f[EMI] = C_c \text{ when EMI is mode C}$$

C_a , C_b , and C_c are universal secret constants assigned by the DTLA. The values for these constants are specified in DTCP specification available under license from DTLA.

6.2.2.1.1 M6 Related Key and Constant Sizes

The following table details the length of the keys and constants described in this chapter:

Key or Constant	Size (bits)
Exchange Key (K_X)	96
Session Exchange Key (K_S)	96
Scrambled Exchange Key (K_{SX})	96
Constants (C_a , C_b , C_c)	96
Constant C_P	24
Content Key for M6 baseline Cipher (K_C)	56
Nonce for Content Channel (N_C)	64

Table 4 Size of M6 Related Content Management Keys and Constants

6.2.2.2 K_C for AES-128

The Content Key (K_C) is used as the key for the content encryption engine. K_C is computed from the three values shown below:

- Exchange Key (K_X) that is used for all EMIs to protect the content. Note that K_S is used instead of K_X in the following formulas when Session Exchange Key is used.
- A random number N_C generated by the source device using RNG_F which is sent in plain text to all sink devices in asynchronous packet(s).
- Constant value C_a , C_b , or C_c which corresponds to an EMI value in the packet header.

The Content Key is generated as follows:

$$K_C = J\text{-AES}(K_X, f[\text{EMI}], N_C) \quad \text{Where:}$$

$$f[\text{EMI}] \{$$

$$f[\text{EMI}] = C_a \text{ when EMI} = \text{Mode A}$$

$$f[\text{EMI}] = C_b \text{ when EMI} = \text{Mode B}$$

$$f[\text{EMI}] = C_c \text{ when EMI} = \text{Mode C}$$

$$\}$$

C_a , C_b , and C_c are universal secret constants assigned by the DTLA. The values for these constants are specified in DTCP specification available under license from DTLA.

6.2.2.2.1 AES-128 Related Key and Constant Sizes

The following table details the length of the keys and constants described in this chapter:

Key or Constant	Size (bits)
Exchange Key (K_X)	96
Session Exchange Key (K_S)	96
Scrambled Exchange Key (K_{SX})	96
Constants (C_a , C_b , C_c)	96
Initialization Vector Constant (IV_C) see 6.6.2.1	64
Content Key for AES-128 Optional Cipher ⁸ (K_C)	128
Nonce for Content Channel (N_C)	64

Table 5 Length of Keys and Constants (Content Channel Management)

⁸ NOT ESTABLISHED see section 1.10

6.2.3 Alternate Content Key (AK_C)

AK_C shall be used instead of K_C only when CMI is used. K_C specified in other sections shall be replaced with AK_C whenever CMI is used.

6.2.3.1 AK_C for M6

The Alternate Content Key (AK_C) is used as the key for the content encryption engine. AK_C is computed from the four values shown below:

- An Exchange Key (K_X) assigned to each EMI used to protect the content. Note that K_S is used instead of K_X in the following formulas when Session Exchange Key is used.
- Content Management Information (CMI) specified in section 6.4.1.2.
- A random number N_C generated by the source device (using RNG_F for devices that support Full Authentication and RNG_R for devices that support only Restricted Authentication) which is sent in plain text to all sink devices in asynchronous packet(s).
- Constant value C_a, C_b, or C_c, which corresponds to an encryption mode EMI in the packet header.

The Alternate Content Key is generated as follows:

$$AK_C = J(K_{XH}, f[EMI], N_C) \quad \text{where:}$$

$$K_{XH} = [SHA-1(K_X || CMI)]_{lsb_{96}}$$

$$f[EMI] = C_a \text{ when EMI is mode A}$$

$$f[EMI] = C_b \text{ when EMI is mode B}$$

$$f[EMI] = C_c \text{ when EMI is mode C}$$

C_a, C_b, and C_c are universal secret constants assigned by the DTLA. The values for these constants are specified in DTCP specification available under license from DTLA.

6.2.3.1.1 M6 Related Key and Constant Sizes

The following table details the length of the keys and constants described in this chapter:

Key or Constant	Size (bits)
Exchange Key (K _X)	96
Session Exchange Key (K _S)	96
Scrambled Exchange Key (K _{SX})	96
Constants (C _a , C _b , C _c)	96
Constant C _P	24
Alternate Content Key for M6 baseline Cipher (AK _C)	56
Nonce for Content Channel (N _C)	64

Table 6 Size of M6 Related Content Management Keys and Constants

6.2.3.2 AK_C for AES-128

The Alternate Content Key (AK_C) is used as the key for the content encryption engine. AK_C is computed from the four values shown below:

- Exchange Key K_X assigned to each EMI used to protect the content. Note that K_S is used instead of K_X in the following formulas when Session Exchange Key is used.
- Content Management Information (CMI) specified in section 6.4.1.2.
- A random number N_C generated by the source device using RNG_F which is sent in plain text to all sink devices in asynchronous packet(s).
- Constant value C_a, C_b, or C_c which corresponds to an EMI value in the packet header.

The Alternate Content Key is generated as follows:

$$AK_C = J\text{-AES}(K_{XH}, f[EMI], N_C) \quad \text{Where:}$$

$$K_{XH} = [\text{SHA-1}(K_X || \text{CMI})]_{\text{lsb}_{96}}$$

$$f[EMI] \{$$

$$f[EMI] = C_a \text{ when EMI} = \text{Mode A}$$

$$f[EMI] = C_b \text{ when EMI} = \text{Mode B}$$

$$f[EMI] = C_c \text{ when EMI} = \text{Mode C}$$

$$\}$$

C_a, C_b, and C_c are universal secret constants assigned by the DTLA. The values for these constants are specified in DTCP specification available under license from DTLA.

6.2.3.2.1 AES-128 Related Key and Constant Sizes

The following table details the length of the keys and constants described in this chapter:

Key or Constant	Size (bits)
Exchange Key (K _X)	96
Session Exchange Key (K _S)	96
Scrambled Exchange Key (K _{SX})	96
Constants (C _a , C _b , C _c)	96
Initialization Vector Constant (IV _C) see 6.6.2.1	64
Alternate Content Key for AES-128 Optional Cipher ⁹ (AK _C)	128
Nonce for Content Channel (N _C)	64

Table 7 Length of Keys and Constants (Content Channel Management)

⁹ NOT ESTABLISHED See section 1.10

6.3 Protocol Flow

6.3.1 Establishing Exchange Key

After the completion of Full or Restricted Authentication, the source device establishes the Exchange Key(s) described in Section 6.2.1. The following procedure is used for each key:

1. The source device assigns a random value for the particular Exchange Key (K_x) (using RNG_F for devices that support Full Authentication and RNG_R for devices that support only Restricted Authentication) being established.
2. It then scrambles the key K_x using K_{AUTH} resulting in K_{SX} according to the function described in the DTCP Specification available under license from the DTLA.
3. The source device sends K_{SX} to the sink device.
4. The sink device descrambles the K_{SX} using K'_{AUTH} (calculated during Authentication) to determine the shared Exchange Key K_x according to the function described in the DTCP Specification available under license from DTLA.

The source device repeats the above steps for all of the Exchange Keys required between it and the sink device.

Finally, the devices update the SRM if it is determined to be necessary during the Full Authentication process (see Chapter 4). The update procedure is described in Section 7.2.1.

Devices remain authenticated as long as they maintain valid Exchange Keys. The Exchange Key may be repeatedly used to set up and manage the security of copyrighted content streams without further authentication. It is recommended that source devices expire their Exchange Keys when they stop all isochronous output. Additionally, both source and sink devices must expire their Exchange Keys when they are detached from the bus (i.e. enter "isolated" state as described in section 3.7.3.1.1 of IEEE std 1394-1995). The process for expiring Exchange Keys is described Section 8.3.4.3.

6.3.2 Establishing Session Exchange Key

To establish the Session Exchange Key (K_S), the same procedure specified in Section 6.3.1 is used to establish the Session Exchange Key (K_S) except that K_S may only be exchanged using Full Authentication independent of procedure for the Exchange Key (K_x). Source devices are prohibited from sending both K_S and K_x with a single AKE procedure. Sink devices send CHALLENGE subfunction with exchange_key field in which the bit for Session Exchange Key (K_S) is set.

6.3.3 Establishing Content Keys

This section describes the mechanism for establishing the Content Keys (K_C) used to encrypt/decrypt content being exchanged between the source and sink devices. Figure 13 shows an overview of content channel establishment and key management protocol flow.

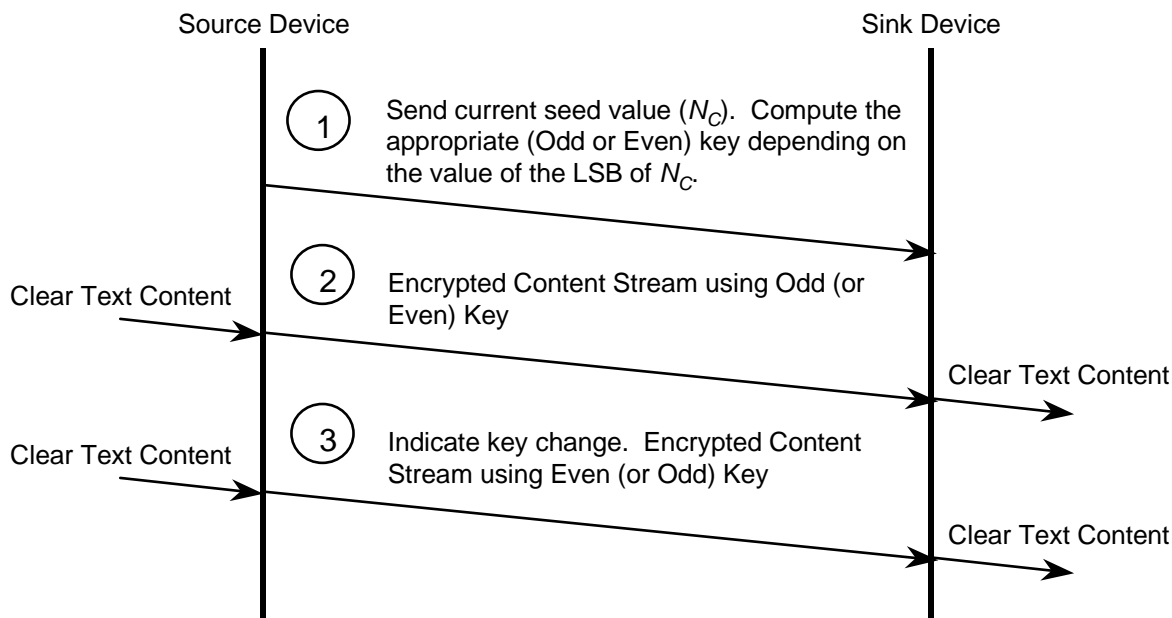

Figure 13 Content Channel Establishment and Management Protocol Flow Overview

Content Keys are established between the source device and the sink device as follows:

1. When the source device starts sending content, it generates a 64 bit random number as an initial value of the seed (N_C) of the Content Key. The initial seed is referred to as Odd or Even based on its least significant bit. If subsequent content channels are established, the current value of N_C from the active content channel(s) shall be used as the seed.
2. The source device begins transmitting the content using the Odd or Even Content Key (K_C) corresponding to the above reference of the initial seed to encrypt the content. The Content Key is computed by the source device using the function J , Exchange Key, the seed (N_C) and the $f[EMI]$. A bit in the IEEE 1394 packet header is used to indicate which key (ODD or EVEN) is being used to encrypt a particular packet of content. If the initial seed is ODD, the Odd/Even bit in the IEEE 1394 packet header is set to Odd; otherwise, it is set to Even.
3. In response to a N_C request from a sink, the source device returns the seed N_C which is used to generate K_C . The sink device computes the current K_C . Note that the least significant bit of N_C may not match the received Odd/Even bit at the sink device (e.g. when sink device requests the seed N_C just before sink observed the Odd/Even update).

The source device computes the next K_C using the same process used for the initial calculation with exception that the seed (N_C) is incremented by $1 \bmod 2^{64}$.

Periodically, the source device shall change Content Keys to maintain robust content protection. To change keys, the source device starts encrypting with the new key computed above and indicates this change by switching the state of the Odd/Even bit in the IEEE 1394 packet header. The minimum period for change of the Content Key is defined as 30 seconds. The maximum period is defined as 120 seconds. Duration time for K_C is from 30 sec to 2 minutes. A source device should not increment the Content Key duration time counter when it is outputting only contents marked with an EMI value (Section 6.4.2) of Copy-free. When a device suspends all isochronous outputs it should reset its counter.

The protocol flow to establish the Content Key using IEEE 1394 transactions is shown in Chapter 8.

6.3.4 Odd/Even Bit

The Odd/Even bit (the 3rd bit of the sync field of the IEEE 1394 isochronous packet header) is used to indicate which Content Key (K_c) is currently being used to protect the content channel. The Odd/Even bit only exists when the value of the tag field is 01. Figure 14 shows this bit location in the packet header. A “0” indicates that the Even key should be used while “1” indicates that the Odd key should be used. The Odd key and Even key are used and updated alternately. The Odd/Even bit can only be changed on Isochronous packets that contain either the beginning of a new encryption frame or are idle packet between encryption frames. If an Isochronous packet contains portions of more than one encryption frame, then the change in key is applied to the first encryption frame which begins in the packet.

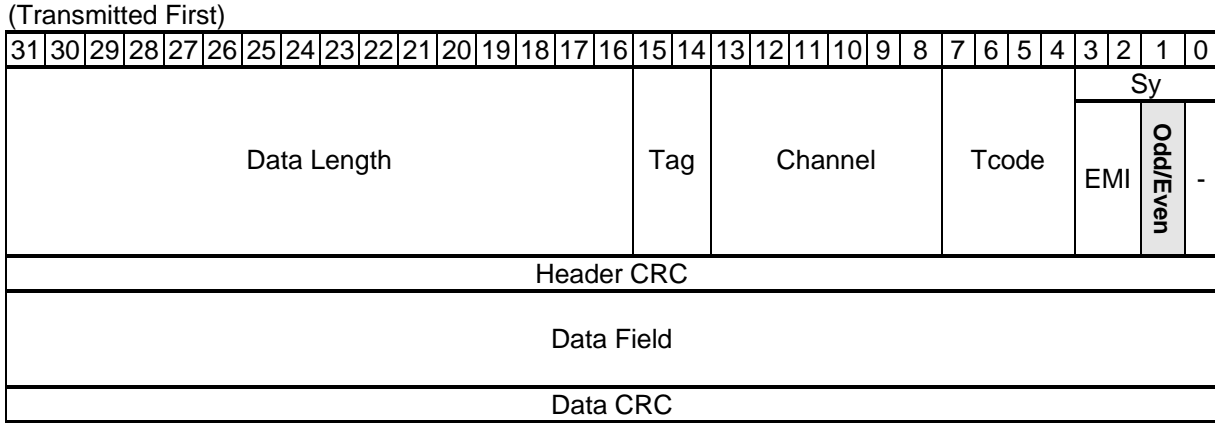

Figure 14 Odd/Even Bit Location in the Packet Header

6.4 Copy Control Information (CCI)

Copy Control Information (CCI) specifies the attributes of the content with respect to this content protection system. Two CCI mechanisms are supported: Embedded CCI and the Encryption Mode Indicator.

6.4.1 Embedded CCI

Embedded CCI is carried as part of the content stream. Many content formats including MPEG have fields allocated for carrying the CCI associated with the stream. Furthermore, the definition and format of the CCI is specific to each content format. In the following sections, Embedded CCI is interpreted to one of four states: Copy Never (11), Copy One Generation (10), No More Copies (01) or Copy Freely (00). The integrity of Embedded CCI is ensured since tampering with the content stream results in erroneous decryption of the content.

6.4.1.1 DTCP_Descriptor for MPEG-TS

The DTCP_Descriptor delivers Embedded CCI over the DTCP system when an MPEG-Transport Stream (MPEG-TS) is transmitted. Appendix B is a detailed description of this descriptor.

6.4.1.2 Content Management Information (CMI)

The CMI Field is the means to carry usage rules independent of content transmission format. The AKE command used to transmit CMI is defined in Section **Error! Reference source not found.** and the format of CMI Field is defined in Appendix E.

6.4.2 Encryption Mode Indicator (EMI)

The Encryption Mode Indicator (EMI) provides an easy-to-access yet secure mechanism for indicating the CCI associated with a stream of digital content. For IEEE 1394 serial buses, the EMI is placed in the most significant two bits of the Sync field of packet header as shown in Figure 15. The EMI bits only exist when the value of the tag field is 01. By locating the EMI in an easy-to-access location, devices can immediately determine the CCI of the content stream without needing to decode the content transport format to extract the Embedded CCI. This ability is critical for enabling bit-stream recording devices (e.g., digital VCR) that do not recognize and cannot decode specific content formats.

The EMI bits can only be changed on isochronous packets that contain either the beginning of a new encryption frame or are idle packets between encryption frames. If an Isochronous packet contains portions of more than one encryption frame, then the change in EMI is applied to the first encryption frame which begins in the packet.

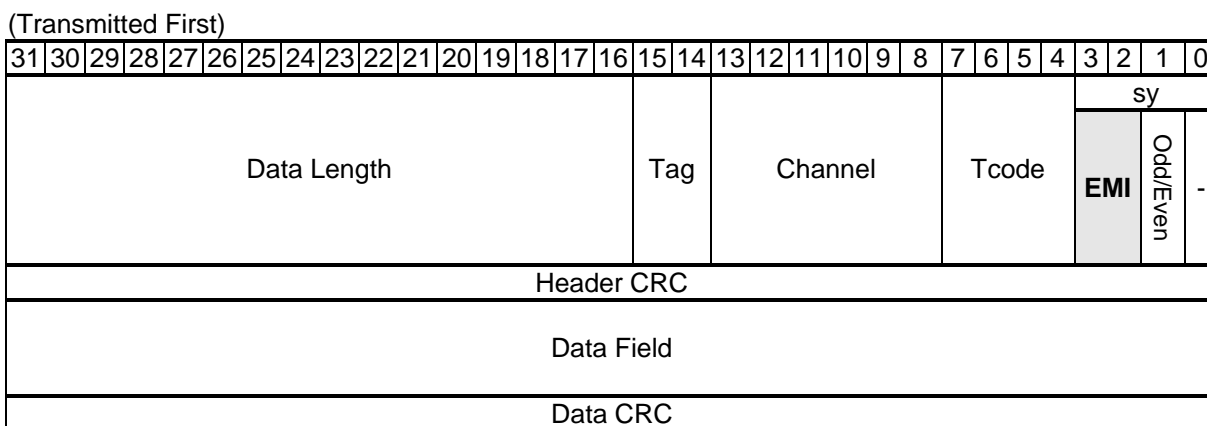

Figure 15 EMI Location

The EMI indicates the mode of encryption applied to a stream:

- Licensed source devices will choose the right encryption mode according to the characteristics of the content stream and set its EMI accordingly. If the content stream consists of multiple substreams with different Embedded CCI, the strictest Embedded CCI will be used to set the EMI.
- Licensed sink devices will choose the right decryption mode as indicated by the EMI.
- If the EMI bits are tampered with, the encryption and decryption modes will not match, resulting in an erroneous decryption of the content.

The following table shows the encoding used for the EMI bits.

EMI Mode	EMI Value	Meaning	Authentication Required
Mode A	11	Copy-never ¹⁰	Full
Mode B	10	Copy-one-generation	Restricted or Full
		Copy-count	Full
Mode C	01	No-more-copies	Restricted or Full
N.A. ¹¹	00	Copy-free	None, not encrypted

Table 8 EMI Encoding

- An encoding of 00 is used to indicate that the content can be copied-freely. No authentication or encryption is required to protect this content.
- For content that is never to be copied (e.g., content from prerecorded media with a Copy Generation Management System (CGMS) value of 11), an EMI encoding of 11 is used. This content can only be exchanged between devices that have successfully completed the Full Authentication procedure.
- An EMI encoding of 10 indicates that one generation of copies or limited number of copies (Copy-count) can be made (e.g. content from prerecorded media with a CGMS value of 10). Devices exchanging Copy-one-generation content can either use Full or Restricted Authentication. Copy-count content can only be exchanged between devices that have successfully completed the Full Authentication procedure.
- If Copy-one-generation content with EMI = 10 is copied, unless otherwise noted future exchanges across a digital interconnect are marked with an EMI encoding of 01, which indicates that a single-generation copy has already been made.

6.4.3 Relationship between Embedded CCI and EMI

A protected stream of content may consist of one or more programs. Each of these programs may be assigned a different level of Embedded CCI. Since EMI is associated with the overall stream of content it is possible that the stream will be composed of multiple programs and that the EMI will not match the Embedded CCI value of each of the protected programs. In the event that there is a conflict, the most restrictive Embedded CCI value will be used for the EMI. [Table 7 The following table](#) shows the allowable combinations of EMI and Embedded CCI:

EMI	Embedded CCI for each program				
	00		01	10	11
	EPN ¹² -not-asserted	EPN ¹² -asserted			
Mode A	Allowed	Allowed	Allowed ¹³	Allowed	Allowed
Mode B	Allowed	Allowed	Prohibited	Allowed	Prohibited
Mode C	Allowed	Allowed	Allowed	Allowed	Prohibited
N.A.	Allowed	Prohibited	Prohibited	Prohibited	Prohibited

Table 9 Relationship between EMI and Embedded CCI

¹⁰ In case of audio transmission (refer to 6.4.5), the meaning of Mode A depends on each AM824 application type as defined in Appendix A.

¹¹ Not Applicable. No EMI mode is defined for an encoding of 00.

¹² Definition and usage of EPN is specified in Appendix B.

¹³ Not typically used.

6.4.4 Treatment of EMI/Embedded CCI for Audiovisual Device Functions

This section presents the behavior of audiovisual device functions according to their ability to send/receive EMI and detect/modify Embedded CCI. Other functions not listed in this section may be permitted as long as they are consistent with the provisions of this specification.

6.4.4.1 Format-cognizant source function

A Format-cognizant source function can recognize the Embedded CCI of a content stream being transmitted. [Table 8](#) [The following table](#) shows the EMI that should be used for a transmitted content stream containing component programs with the following Embedded CCI values:

Embedded CCI of programs					EMI
00		01	10	11	
EPN ¹² -not-asserted	EPN ¹² -asserted				
Don't care	Don't care	* ¹⁴	Don't care	Present	Mode A
Don't care	Don't care	Cannot be Present	Present	Cannot be Present	Mode B
Don't care	Present	Cannot be Present	Don't care	Cannot be Present	
Don't care	Don't care	Present	Cannot be Present ¹⁵	Cannot be Present	Mode C
Present	Cannot be Present	Cannot be Present	Cannot be Present	Cannot be Present	N.A.
Other combinations					Transmission Prohibited

Table 10 Format-Cognizant Source Function CCI handling

6.4.4.2 Format-non-cognizant source function

A Format-non-cognizant source function need not recognize the Embedded CCI of a content stream being transmitted. [Table 9](#) [The following table](#) shows the EMI value that is used by a Format-non-cognizant source function when transmitting content streams with the following EMI:

EMI or recorded CCI ¹⁶ of source content	EMI used for transmission
Copy-never	Mode A
Copy-one-generation	Mode B
No-more-copies	Mode C
Copy-free	N.A.

Table 11 Format-Non-Cognizant Source Function CCI handling

¹⁴ Don't care, but not typically used.

¹⁵ This combination is allowed for format-non-cognizant source function, but is not permitted for format-cognizant source functions.

¹⁶ Recorded CCI is copy control information that is not embedded in the content program and does not require knowledge of the content format to extract.

6.4.4.3 Format-cognizant recording function

A Format-cognizant recording function recognizes the Embedded CCI of a received content program prior to writing it to recordable media. [Table 10-The following table](#) shows the CCI value that is recorded with content programs marked with specific Embedded CCI values.

EMI	Embedded CCI of program			
	00	01	10	11
Mode A	Recordable	Do not record	*17	Do not record
Mode B	Recordable	Discard entire content stream ¹⁸	*17	Discard entire content stream ¹⁸
Mode C	Recordable	Do not record	Do not record	Discard entire content stream ¹⁸

Table 12 Format-cognizant recording function CCI handling

6.4.4.4 Format-cognizant sink function

A Format-cognizant sink function can recognize the Embedded CCI of received content. [Table 11-The following table](#) shows the Embedded CCI of programs contained within the content stream that can be received.

EMI	Embedded CCI of program			
	00	01	10	11
Mode A	Available for processing	Available for processing ¹⁹	Available for processing	Available for processing
Mode B	Available for processing	Discard entire content stream ²⁰	Available for processing	Discard entire content stream ²⁰
Mode C	Available for processing	Available for processing	Available for processing ²¹	Discard entire content stream ²⁰

Table 13 Format-cognizant sink function CCI handling

6.4.4.5 Format-non-cognizant recording function

A Format-non-cognizant recording function can record content with appropriate EMI onto recordable media. [Table 12 The following table](#) shows the EMI value for content that can be recorded and the CCI that should be recorded with the content.

EMI of the received stream	Recorded CCI ²² to be written onto user recordable media
Mode A (Copy-never)	Stream cannot be recorded
Mode B (Copy-one-generation)	No-more-copies
Mode C (No-more-copies)	Stream cannot be recorded

Table 14 Format-non-cognizant recording function CCI handling

6.4.4.6 Format-non-cognizant sink function

For this function, which does not recognize the Embedded CCI, the content must be treated in a manner consistent with its EMI. For example, treatment that does not depend on Embedded CCI is possible.

¹⁷ If the recording function supports recording a CCI value of No-more-copies then the CCI value of No-more-copies shall be recorded with the program. Otherwise the CCI of Copy-never shall be recorded with the program.

¹⁸ If the function detects this CCI combination among the programs it is recording, the entire content stream is discarded.

¹⁹ Not typically used.

²⁰ If the function detects this CCI combination among the programs, the entire content stream is discarded.

²¹ If the device has a rule for handling No-more-copies, this program shall be handled according to the rule. Otherwise the program shall be handled as Copy Never.

²² Recorded CCI is copy control information that is not embedded in the content program and does not require knowledge of the content format to extract.

6.4.5 Treatment of EMI/Embedded CCI Audio Device Functions

This section describes the behavior of audio device functions according to their ability to send/receive EMI and detect/modify Embedded CCI. Refer to Appendix A for specific information about treatment of AM824 audio including specific rules governing the audio application types supported.

For audio transmission, format non-cognizant recording functions are not permitted.

6.4.5.1 Embedded CCI for audio transmission

Three Embedded CCI states are defined for the transmission of audio content as shown in [the following table](#)~~Table 13~~.

Value	Meaning
11	Not Defined
10	Copy-permitted-per-type
01	No-more-copies
00	Copy-free

Table 15 Embedded CCI Values

The copy permission status associated with content marked Copy-permitted-per-type (Value 10) provides flexibility by allowing each audio application to have its own Application Specific Embedded CCI (ASE-CCI). For example, the ASE-CCI for IEC60958 conformant transmission is SCMS.

6.4.5.2 Relationship between Embedded CCI and EMI

In Table 7 the combination of EMI=Mode A and Embedded CCI=01 is allowed, but not typically used.

6.4.5.3 Audio-Format-cognizant source function

Audio-format-cognizant source functions recognize the Embedded CCI of a content stream being transmitted. [Table 14](#)~~The following table~~ shows the EMI that should be used for transmitted content streams containing component programs with the following Embedded CCI values.

Embedded CCI of programs			EMI
00	01	10	
Type specific ²³			Mode A
Don't care	Cannot be present	Present	Mode B
Don't care	Present	Don't care	Mode C
Present	Cannot be present	Cannot be present	N.A.

Table 16 Audio-Format-Cognizant Source Function CCI handling

6.4.5.4 Audio-Format-non-cognizant source function

For this function, the content must be treated in a manner consistent with its EMI.

²³ Usage is format specific, see Appendix A for each AM824 usage.

6.4.5.5 Audio-Format-cognizant recording function

Audio-Format-cognizant recording functions recognizes the Embedded CCI of a received content program prior to writing it to recordable media. [Table 15](#) The following table shows the CCI handling rules for each EMI Mode.

EMI	Embedded CCI of program		
	00	01	10
Mode A	Recordable	Do not record	Recordable ²⁴
Mode B	Recordable	Discard entire content stream ²⁵	Recordable ²⁴
Mode C	Recordable	Do not record	Recordable ²⁴

Table 17 Audio-Format-cognizant recording function CCI handling

6.4.5.6 Audio-Format-cognizant sink function

Audio-format-cognizant sink functions can recognize the Embedded CCI of received content. [Table 16](#) The following table shows the Embedded CCI of programs contained within the content stream that can be received.

EMI	Embedded CCI of program		
	00	01	10
Mode A	Available for processing	Available for processing	Available for processing
Mode B	Available for processing	Discard entire content stream ²⁶	Available for processing
Mode C	Available for processing	Available for processing	Available for processing

Table 18 Audio-format-cognizant sink function CCI handling

6.4.5.7 Audio-Format-non-cognizant recording function

Audio-Format-non-cognizant recording function is not permitted.

6.4.5.8 Audio-Format-non-cognizant sink function

Audio-Format-non-cognizant sink functions shall behave as described in Section 6.4.4.6.

6.5 Common Device Categories

Devices may support zero or more of the functions described in Section 6.4.4.

Common types of fixed function devices include, but are not limited to:

1. **Format-cognizant pre-recorded content source device** has a format-cognizant source function. (e.g., DVD player)
2. **Format-cognizant real-time-delivery content source/decoding device** has a format-cognizant source function and format-cognizant sink function. (e.g., Set Top Box or Digital TV).
3. **Format-cognizant recorder and player** has a format-cognizant source function, format-cognizant sink function, and format-cognizant recording function. (e.g., DV-VCR)
4. **Format-non-cognizant recorder and player** has a format-non-cognizant source function and format-non-cognizant recording function. (e.g., D-VHS VCR)
5. **Format-non-cognizant Bus Bridge** has a format-non-cognizant source function and format-non-cognizant sink function. (e.g., IEEE 1394 to IEEE 1394 bus bridge)

²⁴ The CCI value of No-more-copies shall be recorded with the program. Additional rules for recording are specified by each audio application in the Appendix A.

²⁵ If the function detects this CCI combination among the programs it is recording, the entire content stream is discarded.

²⁶ If the function detects this CCI combination among the programs it is recording, the entire content stream is discarded.

6.6 Content Channel Ciphers

All compliant devices support the baseline cipher and possibly additional, optional ciphers²⁷ for protecting content.

6.6.1 Baseline Cipher

All devices and applications must, at a minimum, support the baseline cipher to ensure interoperability. The M6 block cipher using the converted cipher-block-chaining (C-CBC) mode is the baseline cipher. This cipher is described in detail in DTCP Specification available under license from DTLA.

6.6.2 Optional Cipher (NOT ESTABLISHED³)

Support is defined in Chapter 4 (Device Capability Mask), Chapter 6 (Establishment of multiple K_x values), Chapter 8 (Encoding of cipher selection in the AV/C Digital Interface Command Set).

For optional content channel ciphers, Extended Full authentication is mandatory and therefore the other Authentication procedures (Full, Restricted and Enhanced Restricted) are not used.

6.6.2.1 AES-128 Cipher

For AES-128 as an optional cipher, the Cipher Block Chaining (CBC) mode is used. AES-128 is described in FIPS 197 dated November 26, 2001 and the CBC mode is described in NIST SP800-38A 2001 Edition.

Additional rules for AES-128 Cipher are described in the DTCP Specification available under license from DTLA.

²⁷ NOT ESTABLISHED see section 1.10

6.6.3 Content Encryption Formats

6.6.3.1 For M6

~~Table 17~~ The following table shows the content encryption formats that will be used with content channel ciphers.

Data Format	Encryption Frame	Size
MPEG Transport Stream	IEC61883-4 Transport Stream Packet	188 Bytes
DV (SD Format)	IEC61883-2 Isochronous Transfer Unit	480 Bytes
Rec. ITU-R BO.1516 ²⁸ System B Transport Stream	IEC61883-7 Transport Stream Packet	140 Bytes
Audio	Two "AM824 data" in IEC61883-6 and its extension specification ²⁹	8 Bytes
BT.601	Source Packet Data in BT.601 Transport Over IEEE-1394 ³⁰	176-960 Bytes ³¹

Table 19 M6 Content Encryption Formats

6.6.3.2 For AES-128

~~Table 20~~ The following table shows the content encryption formats that will be used with content channel ciphers.

Data Format	Encryption Frame	Size
MPEG Transport Stream	IEC61883-4 Transport Stream Packet	188 Bytes
DV (SD Format)	IEC61883-2 Isochronous Transfer Unit	480 Bytes
Rec. ITU-R BO.1516 ²⁸ System B Transport Stream	IEC61883-7 Transport Stream Packet	140 Bytes
Audio	Four "AM824 data" in IEC61883-6 and its extension specification ²⁹	16 Bytes
BT.601	Source Packet Data in BT.601 Transport Over IEEE-1394 ²⁹	176-960 Bytes ³⁰

Table 20 AES-128 Content Encryption Formats

²⁸ This recommendation replaced Rec. ITU-R BO.1294.

²⁹ 1394 Trade Association Document 2001003, Audio and Music Data Transmission Protocol 2.0, August 21, 2001

³⁰ 1394 Trade Association Document 2006020, BT.601 Transport Over IEEE-1394 1.1a, October 2, 2006 is being discussed to be IEC61883-8 standard.

³¹ The size of Source Packet Data is 4 bytes smaller than the Source Packet size. It depends on Video Mode, Compression Mode, and Color Space Mode as defined in BT.601 Transport Over IEEE-1394²⁹

6.7 Additional Functions

This section presents the behavior of additional functions according to EXHIBIT "B" of the "DIGITAL TRANSMISSION PROTECTION LICENSE AGREEMENT.

6.7.1 Move Function

Move function defined by DTLA has two modes, Move-mode and Non-Move-mode. If content is transmitted using Move function, a Source function shall use Move-mode. Otherwise, Non-Move-mode shall be used.

In the case of audiovisual MPEG transmission, the modes are indicated in Appendix B.

In the case of DV format transmission, ISR in SOURCE CONTROL pack can be used to indicate the Move-mode in combination with CGMS in the same pack as shown in following table.

Modes	ISR	CGMS
Move-mode	00 ₂ or 01 ₂	10 ₂
Non-Move-mode	Other combinations	

Table 21 DV Format Move Function Modes

For other transmission formats, Move function is ~~a NOT ESTABLISHED~~ ~~an optional~~ feature³² that is not currently specified.

6.7.2 Retention Function

Retention function defined by DTLA has two modes, Retention-mode and Non-Retention-mode. If content is transmitted for purposes of enabling Retention function, a Source function shall use Retention-mode. Otherwise, Non-Retention-mode shall be used.

In the case of audiovisual MPEG transmissions, the modes are indicated in Appendix B.

In the case of DV format transmission, ISR in SOURCE CONTROL pack³³ can be used to indicate the Retention-mode in combination with CGMS in the same pack as shown in the following table.

Modes	ISR	CGMS
Retention-mode	11 ₂	11 ₂
Non-Retention-mode	Other combinations	

Table 22 DV Format Retention Function Modes

For other transmission formats, Retention function is a NOT ESTABLISHED ~~D feature~~³² ~~feature~~ that is not currently specified.

³² See section 1.10

³³ Refer to "IEC 61834 Helical-scan digital video cassette recording system using 6,35 mm magnetic tape for consumer use (525-60, 625-50, 1125-60 and 1250-50 systems)

Chapter 7 System Renewability

7.1 Introduction

Compliant devices that support Full Authentication can receive and process system renewability messages (SRMs) created by the DTLA and distributed with content. These messages are used to ensure the long-term integrity of the system.

7.1.1 SRM Message Components and Layout

There are several components to a system renewability message (SRM):

- A message **Type** field (4 bits). This field has the same encoding as is used for the certificate type field in device certificates. See Section 4.2.3.1 for a description.
- A message **Generation** field (SRMM) (4 bits). This field specifies the generation of the SRM. It is used to ensure the extensibility of the SRM mechanism. Currently, the only encodings defined are 0 and 1. The maximum size is specified in the DTCP specification available under license from DTLA. Other encodings are currently reserved. The Generation value remains unchanged even if only part of the SRM can be stored by the device (e.g. $X_{SRMC} \leq SRMM$).
- **Reserved** field (8 bits). These bits are reserved for future definition and are currently defined to have a value of zero.
- A monotonically increasing system renewability message **Version Number** (SRMV) (16 bits). This value is exchanged as X_{SRMV} during Full Authentication. This value is not reset to zero when the message generation field is changed.
- Certificate Revocation List (CRL) **Length** (16 bits). This field specifies the size (in bytes) of the CRL including the CRL Length Field (two bytes), CRL Entries (variable length), and DTLA Signature (40 bytes).
- **CRL Entries** (variable sized). The CRL used to revoke the certificates of devices whose security has been compromised. Its format is described in the following section.
- The **DTLA EC-DSA signature** of these components using L^{-1} (320 bits).

The structure of first-generation SRMs is shown in Figure 16. The fields in the first 4 bytes of the SRM comprise the SRM Header.

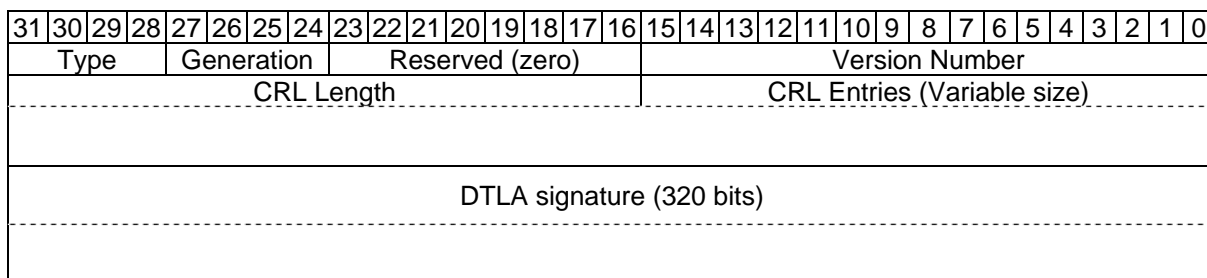

Figure 16 Structure of the First Generation System Renewability Message

7.1.1.1 Certificate Revocation List (CRL)

The **Certificate Revocation List (CRL)** identifies devices that are no longer compliant. It consists of the CRL Length field that specifies the length of the CRL in bytes. This field is followed by a sequence of entry type blocks (1 byte) which are in turn followed by the number of CRL entries specified by the entry type block. The format of the entry type block is as follows:

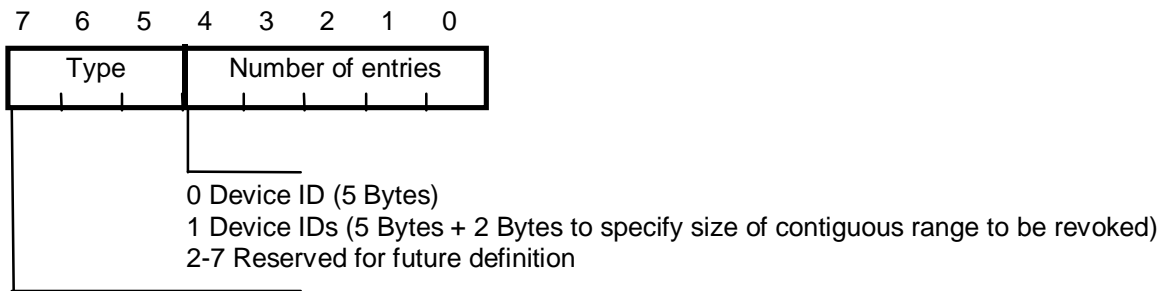

Figure 17 Format of the CRL Entry Type Block

A size encoding of zero for a Type field value of 1 is equivalent to using a Type field encoding of 0.

The end of the CRL is padded with 0 to 3 type entry blocks of value of 00₁₆ to obtain 32-bit alignment.

An example CRL revoking Device IDs AAA, BBB, CCC, DDD – (DDD+18), and EEE – (EEE+16) is shown in Figure 18.

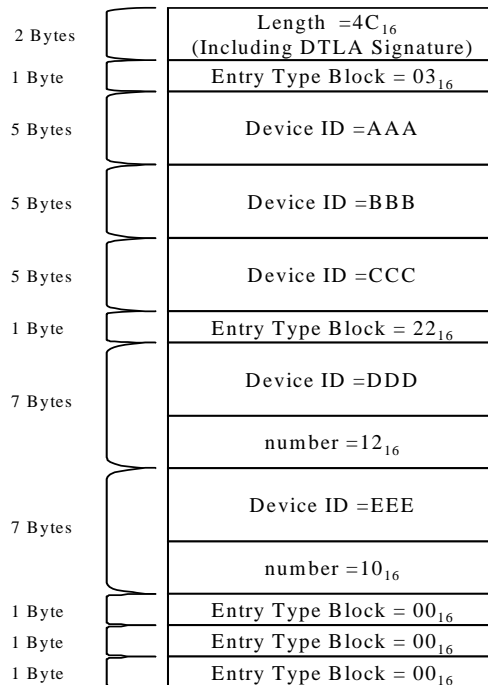

Figure 18 Example CRL

7.1.1.2 DTLA EC-DSA Signature

The DTLA EC-DSA signature field is a 320-bit signature calculated over all of the preceding fields of the SRM using the DTLA EC-DSA private key L⁻¹. This field is used to verify the integrity of the SRM using the DTLA EC-DSA public key L¹.

7.1.2 SRM Scalability

To ensure the scalability of this renewability solution, the SRM format is extensible. Next-generation extensions (CRLs and possibly other mechanisms) to a current-generation SRM format must be appended to the current-generation SRM (as shown in Figure 19) in order to ensure backward compatibility with devices that only support previous-generation SRMs. Devices are only responsible for supporting the generation of SRM that was required by the DTLA as of the time the device was manufactured. The conditions under which the DTLA will authorize a new-generation SRMs are specified in the DTLA license agreement.

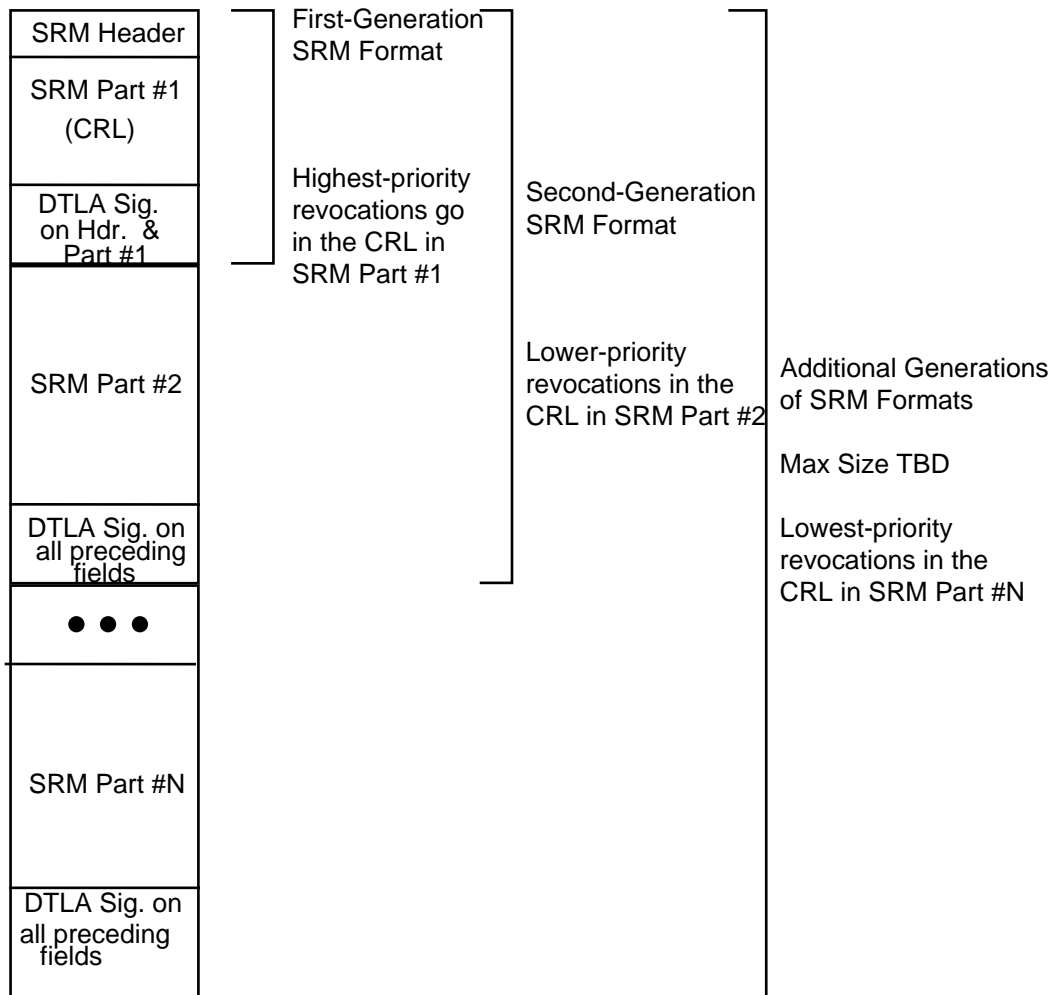

Figure 19 SRM Extensibility

7.2 Updating SRMs

System renewability messages can be updated from:

- other compliant devices (connected via the digital transmission means) that have a newer list.
- prerecorded content media.
- content streams via real-time compliant devices that can communicate externally (e.g., via the Internet, phone line, cable system, direct broadcast satellite, etc.)

The general procedure for updating SRMs is as follows:

1. Examine the version number of the new SRM.
2. Verify that the SRM version number is greater than the one stored in non-volatile storage.
3. Verify integrity with the DTLA public key (L¹).
4. If the SRM is valid and either a more recent version or the same version and larger, then replace the entire currently stored SRM with as much of the newer version of the SRM as will fit in the device's non-volatile storage.

7.2.1 Device-to-Device Update and State Machines

7.2.1.1 Updating a Device's SRM from Another Compliant Device

During the Full Authentication procedure, if a more recent (or more complete) system renewability message is discovered on another device, the following procedure is used to update the device with the outdated and/or less complete copy:

1. The device with the newer and/or more complete SRM sends it to the other device.
2. The device being updated verifies the candidate SRM's signature with the DTLA's public key.
3. If the signature is valid, the device being updated replaces the entire currently stored SRM in its non-volatile storage with as much of the replacement message as will fit in its non-volatile storage.

This procedure should take place following the completion of the exchange of K_x .

A detailed description of the System Renewability protocol and associated state machine can be found in the DTCP Specification available under license from the DTLA.

Chapter 8 AV/C Digital Interface Command Set Extensions

8.1 Introduction

Audio/video devices which exchange content via the IEEE 1394 serial bus are typically IEC61883 and AV/C Digital Interface Command Set compliant. It is important to review Chapters 5, 6, and 7 of the *Specification for AV/C Digital Interface Command Set* (General Specification) for general rules about the AV/C commands and responses.

These specifications define the use of IEEE 1394 asynchronous packets for the control and management of devices and IEEE 1394 isochronous packets for the exchange of content. This chapter describes extensions to the AV/C command set which support the DTCP authentication and key exchange protocols. Extensions to the IEEE 1394 Isochronous packet format are described in Chapter 6.

8.2 SECURITY command

A new Security command is defined for AV/C. This command is intended for content protection purposes including the DTCP system. The general format of the SECURITY command is as follows:

	msb							lsb
Opcode	SECURITY (0F ₁₆)							
Operand[0]	category				(msb)			
Operand[1]	category dependent field							
:								
Operand[X]								

Figure 20 Security command

The value of the Security Command opcode is 0F₁₆. (Common Unit and Subunit command)

The category field for the SECURITY command is defined as follows:

Value	Category
0	Support for DTCP AKE. This command is called the AKE command.
1 - D ₁₆	Reserved for future extension
E ₁₆	Vendor_dependent
F ₁₆	Extension of category field

Figure 21 Security command category field

The value 0 of the category field specifies that this command is used to support the DTCP Authentication and Key Exchange protocols.

The AKE command is defined for the ctype of CONTROL and STATUS. Devices that support the AKE command shall support both ctypes.

The value E₁₆ of the category field specifies that this command is used by vendors to specify their own security commands for licensed use.

8.3 AKE command

The destination of this command is the target device itself. Therefore the 5 bit subunit_type field of an AV/C command/response frame is equal to 11111₂ and the 3 bit subunit_ID field of the frame is equal to 111₂.

8.3.1 AKE control command

The AKE control command is used to exchange the messages required to implement the Authentication and Key Exchange protocols. The format of this command is shown below:

	msb							lsb
Opcode	0F ₁₆							
Operand[0]	category = 0000 ₂ (AKE)				AKE_ID			
Operand[1]	(msb)							
Operand[2]	AKE_ID dependent field							
Operand[3]								
Operand[4]	(lsb)							
Operand[5]	AKE_label							
Operand[6]	number (option)				Status			
Operand[7]	blocks_remaining							(msb)
Operand[8]	data_length							(lsb)
Operand[9]	Data							
:								
Operand[8+]								
data_length]								

Figure 22 AKE Control Command

Both the AKE Command and Response frames have the same opcode and first 9 operands (operand[0-8]). The value of each field in the response frame is identical to that of the command frame except for the status and Data fields. If any of the fields in the first 9 operands contain reserved values, a response of NOT_IMPLEMENTED should be returned.

If a given command frame includes a Data field, the corresponding response frame does not have a Data field. AKE control commands are used to send the information used for the authentication procedure being performed between the source and sink device. This information is sent in the Data field and is called AKE_info. Non-zero values in Reserved fields of AKE_info should be ignored (See Section 8.3.4).

The AKE_ID field specifies the format of the AKE_ID dependent field. Currently only the encoding AKE_ID = 0 is defined. The AKE_ID dependent field for this encoding will be described in Section 8.3.3. The other values, from 1₁₆ to F₁₆, are reserved for future definition.

The AKE_label field is a unique tag which is used to distinguish a sequence of AKE commands associated with a given authentication process. The initiator of an authentication procedure can select an arbitrary value for the AKE_label. The value selected should be different from other AKE_label values that are currently in use by the device initiating the authentication. The same AKE_label value will be used for all control commands associated with a specific authentication procedure between a source and sink device. The AKE_label and source node ID of each control command should be verified to ensure that it is from the appropriate controller.

The optional number field³⁴ specifies the step number of a specific control command to identify its position in the sequence of control commands making up an authentication procedure. The initiator of an authentication procedure sets the value of this field to 1 for the initial AKE control command. The value is incremented for each subsequent command that is part of the same authentication process. When an AKE command must be fragmented for transmission (see the description of the blocks_remaining field below), each fragment will use the same value for the number field. Devices that do not support this field shall set its value to 0000₂.

The status field is used to notify the device issuing the command of the reason when the command results in a REJECTED response. The device issuing the command sets the value of this field to 1111₂. If the responding device rejects the command, it overwrites the status field with a code indicating the reason for rejection. The encoding of the status field is as follows:

³⁴ NOT ESTALBISHED see section 1.10

Value	Status	response code
0000 ₂	No error	ACCEPTED
0001 ₂	Support for no more authentication procedures is currently available	REJECTED
0010 ₂	No isochronous output	REJECTED
0011 ₂	No point to point connection	REJECTED
0100 ₂	DTCP unavailable	REJECTED
0101 ₂	No AC on the specified plug ³⁵	REJECTED
0110 ₂	Unacceptable value in Data field AKE info	REJECTED
0111 ₂	Any other error	REJECTED
1111 ₂	No information	Reserved for INTERIM ³⁶

Figure 23 AKE Control Command Status Field

The following status codes are for testing purposes only. Products shall not return these codes, but instead return 0111₂ (any other error) if these conditions occur.

1000 ₂	Incorrect command order (only for test)	REJECTED
1001 ₂	Authentication failed (only for test)	REJECTED
1010 ₂	Data field syntax error (only for test)	REJECTED

Figure 24 AKE Control Command Status Field Test Values

A detailed description of the usage for each status encoding will be given in Section 8.3.7.

Commands are limited to a maximum length of 512 bytes by the underlying FCP transport. When a given command is larger than the buffers in a controller or target device can accommodate, the `blocks_remaining` field is used to fragment it. (A device issuing a command can determine the size of Data field that the target device can accept using the AKE status command). When this fragmentation is required, the Data field is broken into N blocks that are sent sequentially, each in one of N separate commands, where each command is small enough to be accommodated by the controller's and target's command buffers. At a minimum, these buffers must be able to hold a command with a 32-byte Data field³⁷. The size of the Data field in the first N-1 fragments shall be the same size and a multiple of 16 bytes greater than or equal to 32 bytes.

Each of the N command frames is identical except for the values in the `blocks_remaining`, `data_length`, and Data fields. For the first command, the `blocks_remaining` field is set to the value of N-1. In each successive command, the `blocks_remaining` field is decreased by one until it reaches zero, indicating the last command fragment. If the value of the `block_remaining` field is not correct (e.g., not in the correct order), the target should return a REJECTED response with status field of 0111₂ (Any other error).

When an AKE_info is transmitted using multiple Control Commands, a controller shall send each command only after receiving an ACCEPTED response for the previous command.

The `data_length` field specifies the length of Data field in bytes. Responses to a command will use the same value for their respective `data_length` fields even when the response returns no data. Unless otherwise noted in the description of each subfunction if a response has some data when the response code is ACCEPTED, the corresponding command will have no data but the value of the `data_length` field shall be the same as that of response. If both command and response have some data, the value of the `data_length` field shall be set to the size of data in the command and response frame, respectively.

The Data field contains the data to be transferred. The contents of the Data field depend on the AKE_ID field and the AKE_ID dependent field. For responses with a response code of REJECTED, there is no Data field.

³⁵ This status is used for AC. As for the usage of this status code, refer to section D.4

³⁶ Response with INTERIM response code should not be used except for SET_DTCP_MODE subfunction described in section D.3.3.

³⁷ If future generations of System Renewability Messages (SRMM>0) are defined which have a maximum size larger than 4096 bytes, new devices will be required to support an increase in the minimum buffer size.

8.3.2 AKE status command

The format of the AKE status command is as follows:

	msb							Lsb	
Opcode	0F ₁₆								
Operand[0]	category = 0000 ₂ (AKE)				AKE_ID				
Operand[1]	AKE_ID dependent field								
Operand[2]									(msb)
Operand[3]									
Operand[4]									(lsb)
Operand[5]	FF ₁₆								
Operand[6]	F ₁₆				Status				
Operand[7]	7F ₁₆							(msb)	
Operand[8]	data_length							(lsb)	

Figure 25 AKE Status Command

Both the Command and Response frames have the same structure. The values of each field of the command and response frames are identical except for the AKE_ID dependent, status, and data_length fields.

The AKE_ID field specifies the format of the AKE_ID dependent field. The AKE_ID dependent field for this encoding will be described in Section 8.3.3. Currently, only the encoding of AKE_ID=0 is defined. The other values, from 1₁₆ to F₁₆, are reserved for future definition.

The status field is used by a device to query the state of another device. When the command is issued, the value of this field is set to 1111₂. In the response, the target device overwrites this field with a value indicating its current situation.

Value	Status	Response code
0000 ₂	No error	STABLE
0001 ₂	Support for no more authentication procedures is currently available	STABLE
0010 ₂	No isochronous output	STABLE
0011 ₂	No point to point connection	STABLE
0100 ₂	DTCP unavailable	STABLE
0111 ₂	Any other error	STABLE
1111 ₂	No information ³⁸	REJECTED

Figure 26 AKE Status Command Status Field

The following status codes are for testing purposes only. Products shall not return these codes, but instead return 0111₂ (any other error) if these conditions occur.

1001 ₂	Authentication failed (only for test)	STABLE
-------------------	---------------------------------------	--------

Figure 27 AKE Status Command Status Field Test Values

A detailed description of the usage for each status encoding will be described in Section 8.3.7.

The data_length field specifies the target device's maximum Data field capacity in bytes. When the status command is issued, the value of this field is set to 1FF₁₆. In the response, the target device overwrites this field with a value indicating its current situation. The minimum value to be supported is 020₁₆ (32 bytes).

³⁸ It is recommended that implementers not use the "No information" response.

8.3.3 AKE_ID dependent field (AKE_ID = 0)

When AKE_ID = 0, the format of the AKE_ID dependent field is as follows:

	msb							lsb
Operand[1]	Subfunction							
Operand[2]	AKE_procedure							
Operand[3]	exchange_key							
Operand[4]	subfunction_dependent							

Figure 28 AKE_ID dependent field

The subfunction field specifies the operation of control commands. The most significant bit of the subfunction field indicates whether the control command has data or not.

- If the msb is 0, that command has some data and the data_length field indicates its length.
- If the msb is 1, that command has no data and the data_length field indicates the length of the Data field in response frame whose response code is ACCEPTED.

The subfunctions are described in the DTCP Specification available under license from DTLA. The following table lists currently defined subfunctions:

Value	Subfunction	Comments
01 ₁₆	CHALLENGE	Send random value. This subfunction when sent from a sink device initiates the AKE procedure.
02 ₁₆	RESPONSE	Return data computed with the received random value.
03 ₁₆	EXCHANGE_KEY	Send an encrypted Exchange Key (K _x) to the authenticated contents-sink device.
04 ₁₆	SRM	Send SRM to a device that has an outdated or smaller SRM.
05 ₁₆	RESPONSE2	Return data computed with the received random value and a unique value used to identify the sink device.
06 ₁₆	SET_CMI	Send CMI Field to make Content Key (K _C , AK _C)
C0 ₁₆	AKE_CANCEL	Notify a device that the current authentication procedure cannot be continued.
80 ₁₆	CONTENT_KEY_REQ	Request the data required for making Content Key (K _C).
81 ₁₆	SET_DTCP_MODE	Set DTCP mode: This subfunction is used for AC. Refer to Appendix D.
82 ₁₆	CAPABILITY_REQ	Used to determine the capability of the device.
83 ₁₆	CMI_REQ	Request the data required for making Content Key (K _C , AK _C)
84 ₁₆	CONTENT_KEY_REQ2	Confirm the requested Session Exchange Key is available or not
85 ₁₆	CAPABILITY_REQ2	Used to inform and determine the capability of the device

Table 23 AKE Subfunctions

For status commands, the value of the subfunction field shall be set to FF₁₆.

Each bit of the AKE_procedure field corresponds to one type of authentication procedure, as described in the table below.

Bit	AKE_procedure
0 (lsb)	Restricted Authentication procedure (rest_auth)
1	Enhanced Restricted Authentication procedure (en_rest_auth) ³⁹
2	Full Authentication procedure (full_auth)
3	Extended Full Authentication procedure ⁴⁰ (ex_full_auth, NOT ESTABLISHED ³)
4 - 7 (msb)	Reserved for future extension and shall be zero

Table 24 AKE_procedure values

For the control command, the initiator of an authentication procedure sets one bit in this field to specify which type of authentication will be performed. The value of the field then remains constant through the rest of that authentication procedure.

For the status command the initiator shall set the initial value of this field to FF₁₆. The target will overwrite the field, clearing the bits that indicate the authentication procedures that the target does not support as a source device. For example, if a source device supports both Full Authentication and Enhanced Restricted Authentication, the values of the AKE_procedure field would be set to 06₁₆.

Sink devices should investigate which authentication procedures a source device supports using the status command prior to starting the authentication protocol. The following table shows how to select the appropriate authentication procedure:

Source supported Authentication Procedures	Sink supported authentication procedures		
	Rest_auth and En_rest_auth	Rest_auth and Full_auth	Rest_auth, Full_auth and Ex_full_auth
Rest_auth	Restricted Authentication	Restricted Authentication	Restricted Authentication
En_rest_auth and Full_auth	Enhanced Restricted Authentication	Full Authentication	Full Authentication
En_rest_auth, Full_auth and Ex_full_auth	Enhanced Restricted Authentication	Full Authentication	Extended Full Authentication

Table 25 Authentication selection

³⁹ Source devices that support the Full Authentication procedure shall verify the device certificate of the sink device and examine the SRM even in Restricted Authentication. This authentication procedure is referred to as Enhanced Restricted Authentication in this chapter.

⁴⁰ Devices that support extended device certificates use the Extended Full Authentication procedure described in this chapter.

Each bit of the exchange_key field corresponds to one (or more) key(s) as described in the table below:

Bit	Exchange_key
0 (lsb)	Exchange Key for M6 Copy-never content (requires Full or Extended Full Authentication)
1	Exchange Key for M6 Copy-one-generation content (any authentication acceptable)
2	Exchange Key for M6 No-more-copies content (any authentication acceptable)
3	Exchange key for AES-128 (requires Extended Full Authentication)
4	Reserved for future extension and shall be zero
5	Session Exchange Key
6 – 7 (msb)	Reserved for future extension and shall be zero

Table 26 Exchange_key values

For the control command, the sink device sets the value of this field at the start of an authentication procedure to specify which Exchange Key(s) will be supplied by the source device after the successful completion of the procedure. For Full Authentication any bit can be set for M6. For Restricted Authentication, only one bit for Copy-one-generation or No-more-copies shall be set. This field remains constant for the remainder of the authentication procedure except when the EXCHANGE_KEY subfunction is performed.

For the status command, the initiator shall set FF₁₆ in this field, and target shall clear every bit of the field that corresponds to an Exchange Key that the target cannot supply.

Session Exchange Key is available only when the value of Bit 5 is set to one.

For example, if target can supply three keys that correspond to bit0 through bit2 in the table above, the value of the exchange_key field will be set to 07₁₆.

A sink device should decide which key(s) it will require by getting this information in advance of the authentication procedure with the status command.

The definition of the subfunction_dependent field varies. The DTCP Specification available under license from the DTLA describes the definitions for control commands. For status commands the value of this field is set to FF16 for both the command and response frames.

8.4 Bus Reset Behavior

If the source device continues to transmit content on an isochronous channel following a bus reset, the same Exchange Keys and Content Keys shall be used as were in use prior to the reset.

If a bus reset occurs during an authentication procedure, both the source and sink devices shall immediately stop the authentication procedure. Following the reset, the Source Node ID (SID) field in the CIP header may have changed requiring the sink device to restart the authentication procedure using the new SID.

8.5 Action when Unauthorized Device is Detected During Authentication

After returning an ACCEPTED response to an initiator of a command, the target examines the AKE_information. If the target determines that the initiator is an unauthorized device then the target shall immediately stop the AKE procedure without any notification.

8.6 Authentication AV/C Command Flows

The following figures illustrate the AV/C command flows used for Full and Enhanced Restricted/Restricted Authentication. Refer to Chapters 4, 5, and 6 for the specific ordering relationships between the various messages.

8.6.1 Figure Notation

Solid lines indicate command/response pairs that are always performed.

Dashed lines indicate command/response pairs that are performed on a conditional basis.

8.6.2 Full Authentication Command Flow

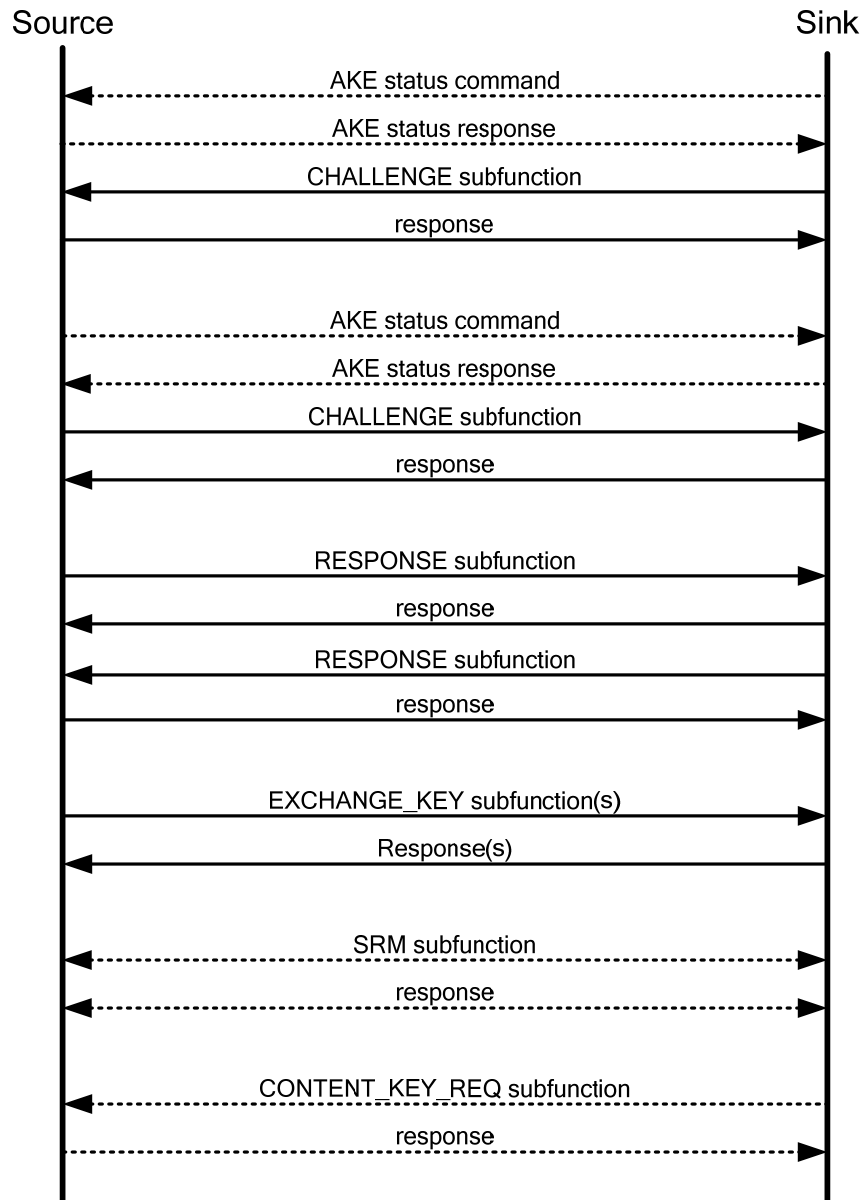

Figure 29 Full Authentication Command Flow

8.6.3 Enhanced Restricted / Restricted Authentication Command Flow

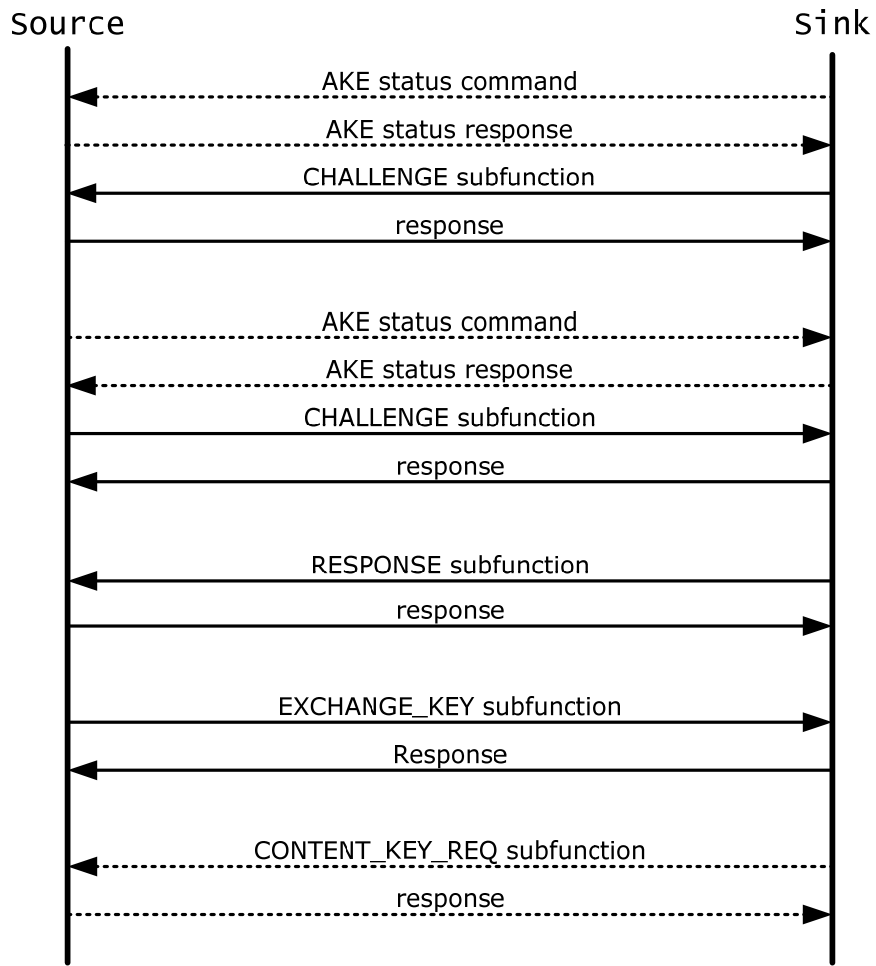

Figure 30 Enhanced Restricted/Restricted Authentication Command Flow

Appendix A Additional Rules for Audio Applications

Only AM824 is specified for audio transport, other formats are to be specified.

A.1 AM824 Audio

This section describes the behavior of AM824 audio device functions according to their ability to send/receive EMI and detect/modify Embedded CCI. AM824 is an audio content format that is transmitted according to the IEC61883-6 specification⁴¹ and its extension specification⁴².

For AM824 audio transmission, devices supporting DTCP shall distinguish between application types by detecting the LABEL value.⁴³

For AM824 audio transmission, the combination of EMI=mode A and Embedded CCI=01 is permitted and may be used. Mode A is used for content that requires System Renewability as described in Chapter 7.

A.1.1 Type 1: IEC 60958 Conformant Audio

A.1.1.1 Definition

IEC 60958 conformant audio applications have a LABEL value of 00₁₆-3F₁₆. IEC61937 data can also be transmitted using Type 1.

A.1.1.2 Relationship between ASE-CCI and Embedded CCI

This application type utilizes three values of Embedded CCI: Copy-free, Copy-permitted-per-type, and No-more-copies. SCMS states are used as the ASE-CCI. The mappings between SCMS states as specified by IEC60958 are mapped to the Embedded CCI values as shown in following table.

SCMS State	Embedded CCI Value
Recordable (Copy free)	00 (Copy-free)
General	00 (Copy-free)
Recordable, set L bit to "Home copy" (Copy once)	10 (Copy-permitted-per-type)
Not recordable (Copy prohibited)	01 (No-more-copies)

Table 27 Relationships between SCMS State and Embedded CCI

A.1.1.3 Usage of Mode A (EMI=11)

The usage of Mode A for this application type is not currently specified.

⁴¹ Consumer Audio/Video Equipment -Digital Interface - Part 6: Audio and music data transmission protocol.

⁴² 1394 Trade Association Document 2001003, Audio and Music Data Transmission Protocol 2.0, August 21, 2001.

⁴³ LABEL value is defined by the IEC61883-6 specification and its extension specification.

A.1.2 Type 2: DVD-Audio

A.1.2.1 Definition

DVD-Audio applications have a LABEL value of 48₁₆-4F₁₆ (for Audio data) and D0₁₆ (for ancillary data). ASE-CCI is transmitted as ancillary data.

A.1.2.2 Relationship between ASE-CCI and Embedded CCI

This application type utilizes three values of Embedded CCI: Copy-free, Copy-permitted-per-type and No-more-copies. audio_copy_permission⁴⁴, audio_quality⁴⁴, audio_copy_number⁴⁴, and ISRC_status⁴⁴, UPC_EAN_ISRC_number⁴⁴, and UPC_EAN_ISRC_data⁴⁴ are used as ASE-CCI. The following table shows relationship between ASE-CCI and Embedded CCI.

ASE-CCI			Embedded CCI
audio_copy_permission	audio_quality	audio_copy_number, ISRC_status, UPC_EAN_ISRC_number, and UPC_EAN_ISRC_data	
11 (No More Copies)	don't care	don't care	01 (No-more-copies)
10 (Copying is permitted per "audio_copy_number")	*45	don't care	01 (No-more-copies)
	*46	refer to rule 2 of section A.1.2.4	10 (Copy-permitted-per-type)
00 (Copy Freely)	don't care	don't care	00 (Copy-free)

Table 28 DVD Audio, Relationship between ASE-CCI and Embedded CCI

A.1.2.3 Usage of Mode A (EMI=11)

Mode A shall be used only for a stream which contains one or more of the following programs:

- Audio quality of the transmitted program does not meet the requirements specified by the audio_quality, and
- The value of audio_copy_permission is 10₂.

A.1.2.4 Additional rules for recording

- 1) AM824 Audio Format-cognizant-recording functions shall not request Exchange Keys⁴⁷ for Mode A and Mode C.
- 2) An AM824 Audio Format-cognizant recording function shall comply with the rules for number of permitted copies specified by section 7.2 of "DVD Specifications for Read-Only Disc Part 4: AUDIO SPECIFICATIONS Version 1.2."

⁴⁴ Refer to section 7.2 of "DVD Specifications for Read-Only Disc Part 4: AUDIO SPECIFICATIONS Version 1.2.

⁴⁵ Audio quality of the transmitted program does not meet the requirements specified by the audio_quality.

⁴⁶ Audio quality of the transmitted program meets the requirements specified by the audio_quality.

⁴⁷ See Section 6.2.1.

A.1.3 Type 3: Super Audio CD

A.1.3.1 Definition

The Super Audio CD audio application has a LABEL value of 50_{16} , 51_{16} and/or 58_{16} (for audio data) and $D1_{16}$ (for ancillary data). Application specific embedded CCI is transmitted as ancillary data.

A.1.3.2 Relationship between ASE-CCI and Embedded CCI

This application type utilizes one value of Embedded CCI: No-more-copies and both Track_Attribute⁴⁸ and Track_Copy_Management⁴⁸ are used as ASE-CCI in this revision of this specification. The following table shows relationship between ASE-CCI and Embedded CCI.

ASE-CCI		Embedded CCI
Track_Attribute	Track_Copy_Management	
0000 ₂	All 0	01 (No-more-copies)
Other combinations		* ⁴⁹

Table 29 Super Audio CD, Relationship between ASE-CCI and Embedded CCI

A.1.3.3 Usage of Mode A (EMI=11)

For a stream, that contains one or more of the following programs. Mode A shall be used:

- The value of Track_Attribute 0000₂ and Track_Copy_Management is all 0.
- Other combinations of Track_Attribute and Track_Copy_Management values in this revision of this specification. They are reserved for future enhancement. This provision is subject to revision.

A.2 MPEG Audio

Audio Transmission via MPEG Transport Stream is a NOT ESTABLISHED feature³ that is not currently specified.

⁴⁸ Refer to the Super Audio CD System Description Version 1.2 Part 3.

⁴⁹ These combinations are reserved for future enhancement and the associated Embedded CCI shall be regarded as “No-more-copies” for this revision of this specification. This provision is subject to revision.

Appendix B DTCP_Descriptor for MPEG Transport Streams

Appendix B is a supplement to Section 6.4 Copy Control Information (CCI) which describes a method for carrying CCI in an MPEG-TS transmission.

B.1 DTCP_descriptor

As no standardized method for carrying Embedded CCI in the MPEG-TS is currently available, the DTLA has established the DTCP_descriptor to provide a uniform Data field to carry Embedded CCI in the MPEG-TS. When MPEG-TS format content is protected by DTCP, the DTCP_descriptor shall be used to deliver Embedded CCI information to sink devices.

B.2 DTCP_descriptor syntax

The DTCP_descriptor is defined in accordance with the ATSC_CA_descriptor specified by ATSC⁵⁰ document A/70⁵¹ and is described as follows:

<u>Syntax</u>	<u>Size(bits)</u>	<u>Formats</u> ⁵²	<u>Value</u>
DTCP_descriptor(){			
descriptor_tag	8	uimbsbf	0x88
descriptor_length	8	uimbsbf	
CA_System_ID	16	uimbsbf	0x0fff
for(i=0; i<descriptor_length-2; i++){			
private_data_byte	8	bslbf	
}			
}			

Table 30 DTCP_descriptor syntax

The definition of the private_data_byte field of the DTCP_descriptor is as follows:

<u>Syntax</u>	<u>Size(bits)</u>	<u>Formats</u> ⁵²
Private_data_byte{		
Reserved	1	bslbf
Retention_Move_mode	1	bslbf
Retention_State	3	bslbf
EPN	1	bslbf
DTCP_CCI	2	bslbf
Reserved	3	bslbf
DOT	1	bslbf
AST	1	bslbf
Image_Constraint-Token	1	bslbf
APS	2	bslbf
}		

Table 31 Syntax of private_data_byte for DTCP_descriptor

The DTCP_descriptor allows for future expandability should it become necessary to add newly defined Embedded CCI. In the event that additional Embedded CCI is defined by the DTLA to support additional functionality, the length of the private_data_byte field and the descriptor_length value may be extended. If this occurs, currently defined fields in the private_data_byte shall not be altered to ensure backward compatibility. All devices shall be designed so that any change to the descriptor_length value that results from an extension of the private_data_byte field shall not prevent access to contents of the private_data_byte defined as of the time the device is manufactured.

⁵⁰ Advanced Television Systems Committee

⁵¹ Conditional Access System for Terrestrial Broadcast (A/70) ATSC standard

⁵² as described in the definition of ISO/IEC 13818-1

B.2.1 private_data_byte Definitions:

Retention_Move_mode

This field is used to indicate the mode of the Move function or the Retention function in combination with the DTCP_CCI as shown in following tables.

Modes	Retention_Move_mode	DTCP_CCI
Move-mode	0 ₂	10 ₂
Non-Move-mode	Other combinations	

Table 32 Move Function Modes

Modes	Retention_Move_mode	DTCP_CCI
Retention-mode	0 ₂	11 ₂
Non-Retention-mode	Other combinations	

Table 33 Retention Function Modes

Retention_State^{53,54}

This field indicates the value of the Retention_State.

Retention_State_Indicator	Retention Time
000 ₂	Forever
001 ₂	1 week
010 ₂	2 days
011 ₂	1 day
100 ₂	12 hours
101 ₂	6 hours
110 ₂	3 hours
111 ₂	90 minutes

Table 34 Retention States

Encryption Plus Non-assertion (EPN)⁵³

This field indicates the value of the EPN.

EPN	Meaning
0 ₂	EPN-asserted
1 ₂	EPN-unasserted

Table 35 EPN

⁵³ Definition and usage are specified in EXHIBIT “B” of the “DIGITAL TRANSMISSION PROTECTION LICENSE AGREEMENT”

⁵⁴ If an inter-industry standard or consensus supports retention states that differ from those set forth in this Specification, then this Specification may be amended or supplemented to reflect such consensus retention states.

DTCP_CCI

This field indicates the copy generation management information.

DTCP_CCI	Meaning
00 ₂	Copy-free
01 ₂	No-more-copies
10 ₂	Copy-one-generation
11 ₂	Copy-Never

Table 36 DTCP_CCI

Digital_Only_Token (DOT)

The field indicates the value of the DOT.

DOT	Meaning
0 ₂	DOT-asserted
1 ₂	DOT-unasserted

Table 37 DOT

Analog_Sunset_Token (AST)

The field indicates the value of the AST.

AST	Meaning
0 ₂	AST-asserted
1 ₂	AST-unasserted

Table 38 AST

Image_Constraint_Token⁵⁵

This field indicates the value of the Image_Constraint_Token.

Image_Constraint_Token	Meaning
0 ₂	High Definition Analog Output in the form of Constrained Image
1 ₂	High Definition Analog Output in High Definition Analog Form

Table 39 Image_Constraint_Token

APS⁵⁶

This field indicates the analog copy protection information.

APS	Meaning
00 ₂	Copy-free (APS off)
01 ₂	APS is on : Type 1 (AGC)
10 ₂	APS is on : Type 2 (AGC + 2L Colorstripe ⁵⁷)
11 ₂	APS is on : Type 3 (AGC + 4L Colorstripe ⁵⁷)

Table 40 APS

reserved : These bits are reserved for future definition and are currently defined to have a value of one.

⁵⁵ Definition and usage of the Image Constraint Token is specified in EXHIBIT "B" of the "DIGITAL TRANSMISSION PROTECTION LICENSE AGREEMENT"

⁵⁶ as described in the Specification of the Macrovision Copy Protection Process for DVD Products, Revision 7.1.D1, September 30, 1999

⁵⁷ 2L/4L Colorstripe is applicable on for NTSC analog output.

B.3 Rules for the Usage of the DTCP_descriptor

B.3.1 Transmission of a partial MPEG TS⁵⁸

When a partial MPEG-TS that includes one or more programs is transmitted using DTCP, Format-cognizant source function shall insert the DTCP_descriptor into the PMT⁵⁹ of each program for which the CCI is not Copy-free or EPN assertion is required. When the DTCP_descriptor is inserted, it shall only be applied to the PMT.

A Format-cognizant source function shall set the DTCP_CCI bits, APS bits, and any other Embedded CCI defined by the DTLA within the DTCP_descriptor according to the CCI provided for each program within the MPEG-TS. The DTCP_descriptor shall be inserted into the program_info loop of the relevant PMT.

Additionally, if any of the Elementary Streams within a program are assigned specific CCI values, format-cognizant source function shall set the DTCP_CCI bits, APS bits, and any other Embedded CCI defined by the DTLA within the DTCP_descriptor according to that CCI. The DTCP_descriptor shall be inserted into the ES_info loop of the relevant PMT for the Elementary Stream.

When the DOT field is set to zero (DOT-asserted) in the DTCP_descriptor, source functions shall use the following K_{XHO} instead of K_X to calculate the Content Key (K_C), and the source functions shall set 1001_2 to the cipher_algorithm field in the response of CONTENT_KEY_REQ subfunction and CMI_REQ subfunction while they use K_{XHO} for the Content Key.

$$K_{XHO} = \text{SHA-1}[K_X]_{\text{lsb}_{96}}$$

This operation does not apply to the Session Exchange Key.

K_{XHO} shall not be used for content transmission using the CMI even if the DOT field is set to zero in the DTCP_descriptor. ~~or any other purpose than the calculation of K_{XHO}~~ [is only used to calculate the Content Key \(\$K_C\$ \).](#)

B.3.2 Transmission of a full MPEG TS

When a full MPEG-TS is transmitted with DTCP protection, the same rules as for partial MPEG-TS are applied for all the programs within the TS.

B.3.3 Treatment of the DTCP_descriptor by the sink device

This section describes the treatment of the DTCP_descriptor when received by a sink device. When the function of the sink device is format cognizant and receives recognizable Embedded CCI other than the DTCP_descriptor within an MPEG-TS, the alternative Embedded CCI shall take precedence over the information contained within the DTCP_descriptor. Furthermore, the DTCP_descriptor is only valid when it is inserted into the PMT. If a DTCP_descriptor is found in another location, it shall be ignored.

When the only Embedded CCI detected is the DTCP_descriptor, the DTCP_descriptor shall be regarded as the Embedded CCI described in Sections 6.4.4.3 and 6.4.4.4 and interpreted as follows:

If a DTCP_descriptor is found in an ES_info loop of the PMT, the Embedded CCI value contained in the DTCP_descriptor should only be used as the CCI for the specific ES for which the DTCP_descriptor is associated.

If a DTCP_descriptor is not found in the ES_info loop for a specific ES, but is instead found in the program_info loop, the Embedded CCI values contained within the DTCP_descriptor shall be used as the CCI for that ES.

A program in a stream shall be regarded as Copy-free if the stream contains multiple programs and neither Embedded CCI nor DTCP_descriptor are detected in the program and a DTCP_descriptor is detected in another program on the same stream.

⁵⁸ as described in the definition of EN 300 468

⁵⁹ as described in the definition of ISO/IEC 13818-1

Appendix C Limitation of the Number of Sink Devices Receiving a Content Stream

Without exception, the number of authenticated sink devices, including those connected via bus bridge devices receiving content from a Full Authentication capable source device shall be limited to no more than 34 devices at any time.

C.1 Limitation Mechanism in Source Device

A source device that has a Full Authentication capability shall count the number of sink device using a Sink Counter. The source device shall increment the Sink Counter and register the Device ID after successful AKE⁶⁰ with an unregistered sink device where the sink's device certificate has an AP flag value of zero. The source device shall also increment the Sink Counter after successful AKE regardless of its registration status, when the sink's device certificate has an AP flag value of one. If the source device outputs content to different buses separately, it shall count the number of the sink devices using one Sink Counter.

When the source device expires all Exchange Keys (K_X , see section 6.3.1) and Session Exchange Keys (K_S) (see section 6.3.2), it shall reset the Sink Counter to zero and clear the list of registered Device IDs. When the source device expires all Exchange Keys (K_X) and Session Exchange Keys (K_S) distributed to certain sink device(s), it may decrement the Sink Counter by the number of the sink device(s) and clear registered Device ID(s) of the sink device(s) from the list. When the source device expires all Exchange Keys (K_X) and Session Exchange Keys (K_S) distributed to certain bridge device(s), it may decrement the Sink Counter by the number of successful AKE with the bridge device(s). Except for these cases, a source device shall not decrease nor reset its Sink Counter.

When the Sink Counter reaches the prescribed maximum limit of 34, the source device shall reject any further authentication requests from both unregistered sink devices with a device certificate having an AP flag value of zero and sink devices with a device certificate having an AP flag value of one with the status code of 0111₂ "Any other error". This status code should not be used for other commands to indicate that the Sink Counter is 34.

⁶⁰ Successful AKE means after source device sends Exchange Keys (K_X or K_S).

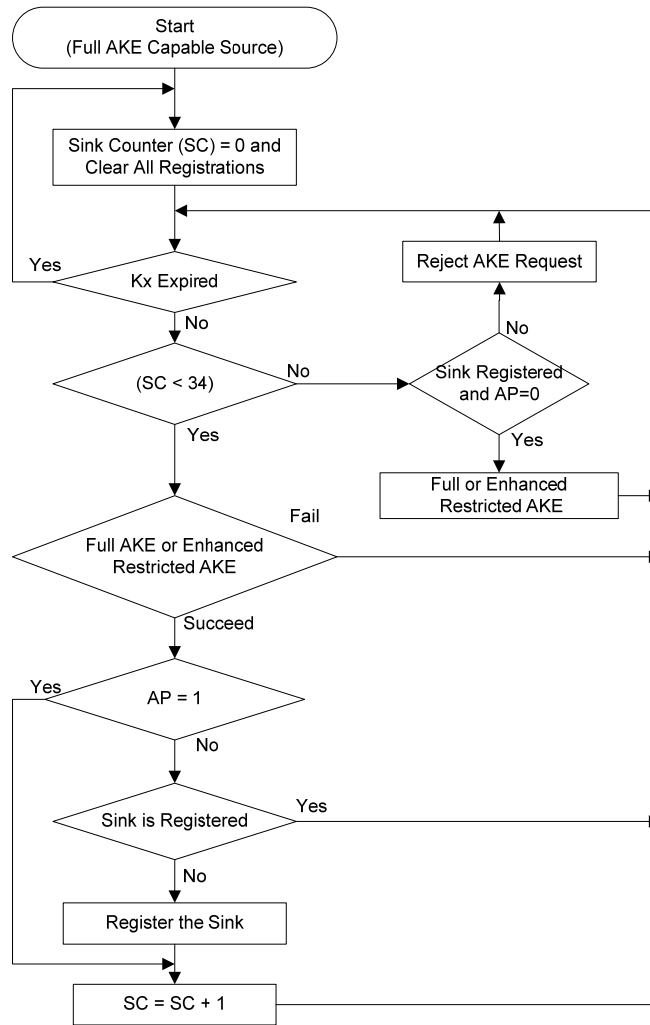

Figure 31 Sink Counter Algorithm (Informative)

When a source device that has CIH flag value of one receives RESPONSE2 subfunction with NB flag value of one, it shall use ID_j instead of Device ID and regard the value of the AP flag as zero for the above described procedure.

C.2 Limitation Mechanism in DTCP Bus Bridge Device

The DTCP bus bridge device has transcrypting capability which uses a sink function and a source function where the sink function decrypts the received content stream from upstream source(s) and the source function re-encrypts the stream and sends it to downstream sink(s). A DTCP bus bridge device shall have Full Authentication capability and have a device certificate with the AP flag value of one. The bridge performs authentication with the upstream source as a proxy of downstream sink(s).

C.2.1 DTCP Bus Bridge Device Source Function

A DTCP bus bridge device shall count the number of authenticated downstream sink devices receiving the content stream from an upstream source device using a Sink Counter. The bus bridge device's Exchange Keys (K_x) or Session Exchange Keys are those used by its source function.

The bridge device shall increment the Sink Counter and register Device ID after successful AKE with an unregistered downstream sink device with a device certificate having an AP flag value of zero. The bridge device shall also increment the Sink Counter after successful AKE with a downstream sink device, regardless of its registration status, where the downstream sink's device certificate has an AP flag value of one.

The bridge device shall reject the authentication request from both unregistered downstream sink devices having an AP flag of zero and downstream sink devices having an AP flag of one with the status code of 0111_2 "Any other error", when the Sink Counter in the bridge device is equal to the prescribed maximum limit of 34. This status code should not be used for other commands to indicate that the Sink Counter is 34. The bridge device may reject further authentication request from unregistered downstream sink device having an AP flag of zero or a downstream sink device having an AP flag of one with the status code of 0111_2 "Any other error", when it judges a Sink Counter of an upstream source device is 34.

When a DTCP bus bridge device expires all Exchange Keys (K_x) and Session Exchange Keys, it shall reset its Sink Counter to zero and clear the list of registered Device IDs. When the source device expires all Exchange Keys (K_x) and Session Exchange Keys distributed to certain sink device(s), it may decrement the Sink Counter by the number of the sink device(s) and clear registered Device ID(s) of the sink device(s) from the list. When the source device expires all Exchange Keys (K_x) and Session Exchange Keys distributed to certain bridge device(s), it may decrement the Sink Counter by the number of successful AKE with the bridge device(s). Except for this case, a bridge device shall not decrease nor reset its Sink Counter. The bridge device shall not expire its Exchange Key while it outputs any stream.

If a DTCP bus bridge device outputs the content to different buses separately, it shall count the number of the sink device using one Sink Counter.

If a DTCP bus bridge device outputs different content streams to different buses separately, e.g. via two transcrypting capability in a DTCP bus bridge device, the bridge device shall count the number of downstream sink devices using one Sink Counter, as long as the same Exchange Key is used for all of the downstream buses.

When a DTCP bus bridge device that has CIH flag value of one receives RESPONSE2 subfunction with NB flag value of one, it shall use ID_U instead of Device ID and regard the value of the AP flag as zero for the above described procedure.

C.2.2 DTCP Bus Bridge Device Sink Function

A DTCP bus bridge device is strongly encouraged not to execute unnecessary authentication⁶¹, because the Sink Counter in the source device always counts up after every successful AKE if the bridge device uses a device certificate having an AP flag of one for authentication with an upstream source device.

It is recommended that a DTCP bridge device acquires all Exchange keys that the source device can supply in one authentication procedure to avoid unnecessary incrementing of the upstream source device's Sink Counter. When the bridge device's Sink Counter is non-zero and the bridge device has not obtained any Exchange Keys yet from an upstream source device, the bridge device shall 1) complete successive successful AKEs with the upstream source device the same times as the value of the Sink Counter before retransmitting any content streams from the upstream source device or 2) expire its Exchange Keys, reset its Sink Counter and clear the list of registered Device IDs.

⁶¹ For example, if a sink function, which is independent of transcrypting use (refer to C.2.6), in a DTCP bus bridge device repeats authentication using device certificate having AP flag value of one regardless of expiration of Exchange Key(s), the Sink Counter in the source device reaches to 34 even if the bridge device is the only one sink device in the system.

A DTCP bus bridge device may or may not expire its Exchange Key when an upstream source device changes its Exchange Key.

C.2.3 Extra Key handling

An Extra Key makes a DTCP bus bridge device possible to accept one authentication request from an unregistered downstream sink device having an AP flag value of zero or a downstream sink device having an AP flag value of one. To obtain one Extra Key, a DTCP bus bridge device shall complete successful AKEs⁶² only with all upstream source devices that have Full Authentication capability.

The Extra Key is consumed after the successful AKE with the downstream sink.

When a DTCP bus bridge device without an Extra Key receives an authentication request from an unregistered downstream sink device having an AP flag value of zero or a downstream sink device having an AP flag value of one, the bridge device rejects the authentication request with the status code of 0001₂ " Support for no more authentication procedures is currently available", and starts to obtain an Extra Key. To avoid the rejection of the authentication request, a DTCP bus bridge device without Extra Key may start to obtain one Extra Key. A DTCP bus bridge device with an Extra Key is not allowed to start procedure for obtaining additional Extra Key.

C.2.4 Implementation of DTCP bus bridge

A DTCP bus bridge device may count the number of succeeded procedures for obtaining an Extra Key using a Key Counter.

There are two types of DTCP bus bridge device which are differentiated by whether or not they have a Key Counter.

⁶² If the upstream source device does not have Full authentication capability, a DTCP bus bridge device shall count the number of sink devices instead of the source device. Therefore it does not need to request authentication with the source device to obtain an Extra Key.

C.2.4.1 Implementation of DTCP bus bridge device without Key Counter

Without Key Counter, a DTCP bus bridge device can have one Extra Key when the bridge device resets its Sink Counter.

When a DTCP bus bridge device expires its Exchange Key⁶³, the bridge device is recommended to keep its Extra Key as long as the upstream source device uses the same Exchange Key to avoid redundant authentication with the source device.

An informative example of state machine of a DTCP bus bridge device transferring content streams from one source, which does not use Key Counter, is described in Figure 32.

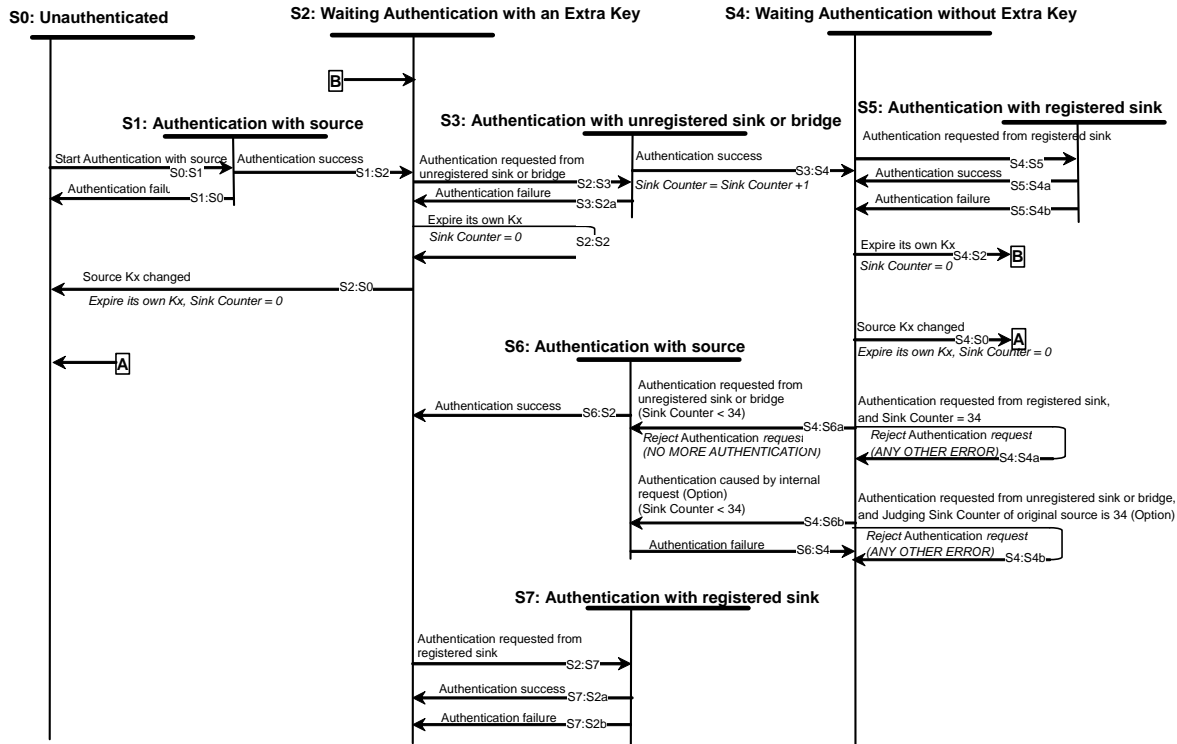

Figure 32 DTCP bus bridge State Machine without Key Counter (Informative)

C.2.4.2 Implementation of DTCP bus bridge device with Key Counter

Using Key Counter, a DTCP bus bridge device can have the same number of Extra Keys as the Key Counter when the bridge device resets its Sink Counter.

When a DTCP bus bridge device expires its Exchange Key, the bridge device is recommended to keep its Key Counter as long as the source device uses the same Exchange Key to avoid redundant authentication with the source device.

A DTCP bus bridge device shall reset its Key Counter to zero when there is only one upstream source device and the upstream source device expires all Exchange Keys (K_x and K_s).

Before retransmission of the content stream from the upstream source device, the bridge device shall complete successive successful Extra Key procedure(s) with the source device until its Key Counter is not less than its Sink Counter, or expire its own Exchange Keys⁶⁴.

An informative example of state machine of a DTCP bus bridge device transferring content streams from one source, which uses Key Counter, is described in Figure 33.

⁶³ Note that expiring Exchange Key in a DTCP bridge device without Key Counter may cause redundant sink counting in the upstream source device that keeps using its Exchange Key.

⁶⁴ If the bridge device cannot increment its Key Counter up to its Sink Counter for some reason such that the authentication is not succeeded, the bridge device is recommended to expire its Exchange Keys.

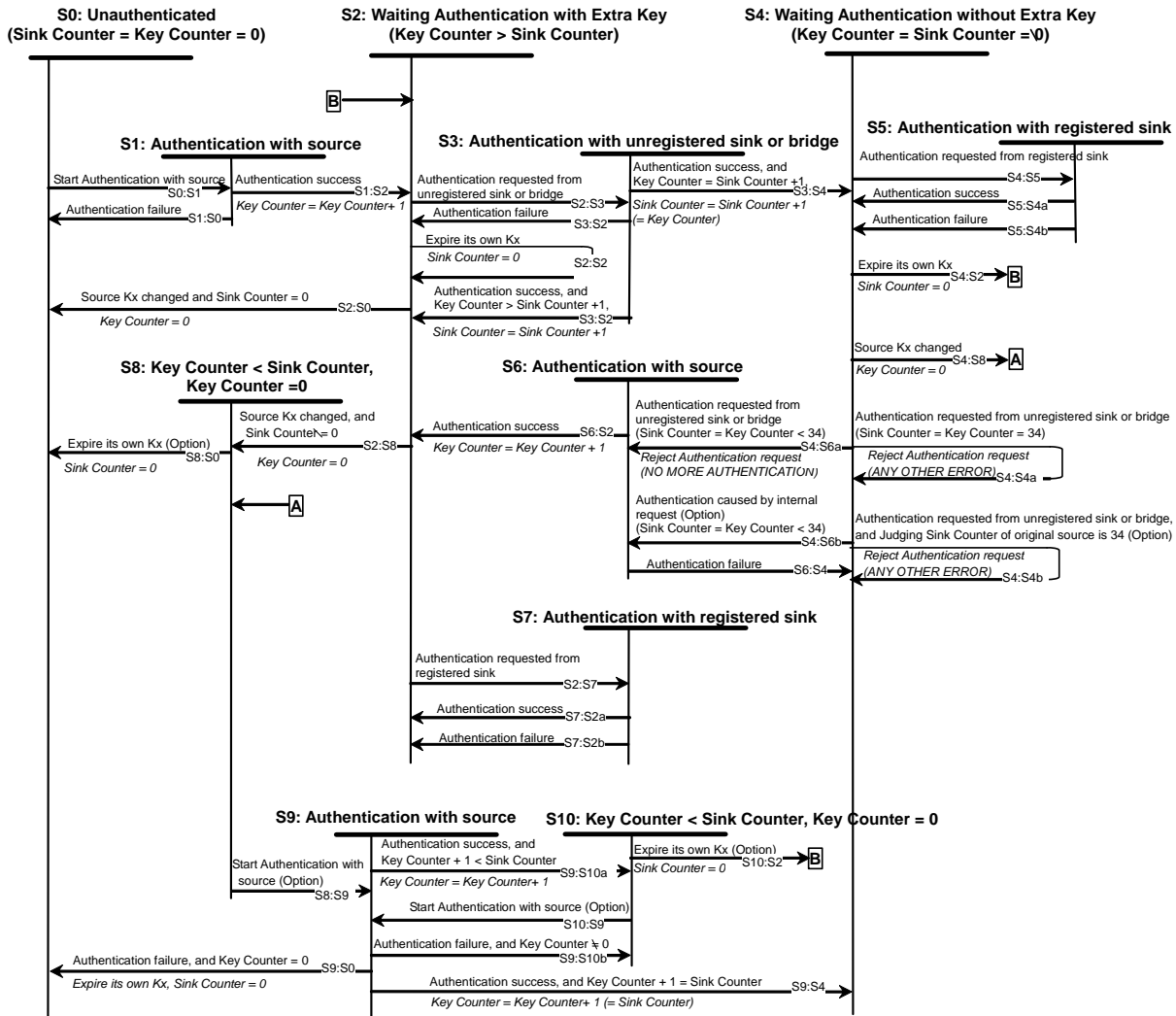

Figure 33 DTCP bus bridge State Machine with Key Counter (Informative)

C.2.5 Additional device certificate in a DTCP bus bridge device

A DTCP bus bridge device may have device certificate with the AP flag value of zero in addition to the device certificate with the AP flag value of one. The device ID of these two device certificates are different each other.

A DTCP bus bridge device may request an authentication to an upstream source device using device certificate with the AP flag =0 for avoiding unnecessary count up of the Sink Counter in the source device.

In this case, Exchange Key(s) obtained by the authentication shall be used for the sink function independent of transcribing use in the bridge device, or shall be treated as a successful AKE for obtaining one Extra Key regardless of the times the bridge device obtains the same Exchange Key(s).

C.2.6 Treatment of additional function in a DTCP bus bridge device

A DTCP bus bridge device may also have recording function or source / sink function independent of transcribing use.

If the DTCP bus bridge device has recording function or sink function independent of transcribing use, the bridge device shall count the bridge device as an authenticated downstream sink device using the Sink Counter.

If the DTCP bus bridge device has source function independent of transcribing use, the source function shall count⁶⁵ the number of authenticated downstream sink devices receiving the content stream according to the rules described in Appendix C.1.

⁶⁵ Note that if the DTCP bus bridge device outputs content stream from both an upstream source device and the source function in the bridge device to the same downstream bus, the number of authenticated downstream sink devices for the source function is also limited by the upstream source device's sink number limitation, because Extra Key is needed.

Appendix D DTCP Asynchronous Connection

D.1 Purpose and Scope

Appendix D specifies the mechanisms to use DTCP for Asynchronous Connection (AC). All aspects of the IEEE 1394 DTCP isochronous functionally described in Volume 1 body and the other Appendices are preserved and this appendix only details AC specific rules or additions.

D.2 Transmission of Protected Frame

D.2.1 Overview

Frame is minimal transmission unit of AC. Before transmitting a Frame, AC between Producer (source device of AC) and Consumer (Sink device of AC) is established using AV/C commands. One or more Frames are transmitted from the Producer to the Consumer. After the Frame transmission, the AC is broken using AV/C command. AC does not specify the size of the Frame. AC does not use special header when transmitting the Frame. Only the Frame data is transmitted.

In case of DTCP-AC, DTCP specific information such as EMI, Odd/Even bit shall be transmitted. To transmit this information together with Frame data, Protected Content Packet is introduced. In case of DTCP-AC, the Producer converts a Frame to Protected Frame and transmitted it to the Consumer.

In this section, Protected Frame is defined and transmission methods for Protected Frame are specified.

D.2.2 Protected Content Packet

Protected Content Packet is used to carry the Frame in DTCP-AC. Figure 34 shows the structure of Protected Content Packet.

	msb						lsb
Header [0]	Reserved (zero)						(msb)
Header [1]	dp_length (9 bits 2-504)						(lsb)
Header [2]	Reserved (zero)						
Header [3]	Reserved (zero)			EMI	Odd/Even	Reserved (zero)	
Header [4] : Header [7]	Reserved (zero)						
PC[0]	Protected Content (8xN bytes: N=1-63) ⁶⁶						
-							
-							
-							
PC[8N-1]							

Figure 34 Structure of Protected Content Packet

Protect Content Packet has eight bytes header (PCP header) and Protected Content. PCP header has following field.

dp_length: the value of this field shows the size of Data Packet in bytes (2-504).

EMI: Refer to section 6.4.2

Odd/Even: Refer to section 6.3.3

Protected Content (i.e. Encryption Frame) consists of a Data Packet and zero padding bytes which are encrypted according to the value of EMI. The size of Protected Content is multiple of 8 bytes. Figure 35 shows the structure of Data Packet.

⁶⁶ In case of AES-128 optional cipher, N=2-63.

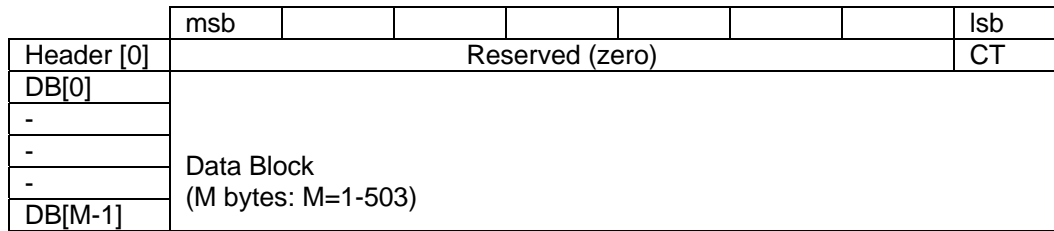

Figure 35 Structure of Data Packet

Data Packet has one byte header (DP header) and a Data Block. DP header has following field.

CT (Content Type): specifies the treatment of EMI/Embedded CCI for the Data Block in the Data Packet and the value of which are described in following table:

CT	Definition	Meaning
0 ₂	Audiovisual Content	Rules for audiovisual device functions described in Section 6.4.4 are applied
1 ₂	Audio Content	Rules for audio device functions described in Section 6.4.5 are applied

Table 41 Content Type

Data Block contains a part of the data in the Frame to be transmitted through DTCP-AC.

D.2.3 Construction of Protected Frame

When a Frame is transmitted using DTCP, the Frame is divided into one or more Data Blocks from the top of the Frame. The maximum size of the Data Block is 503 bytes. When the value of EMI and CT are not changed in the middle of the Frame, the size of all Data Blocks is 503 byte except the last one which may contain less than 503 byte. When the value of EMI and/or CT is changed in the middle of the frame, the size of the Data Block before the changing point may contain less than 503 byte, so that a Data Packet contains the data which has the same EMI and the same CT.

Data Packet consists of one byte DP header and a Data Block. Data Packet size is within the inclusive range of 2 to 504bytes. If the size of the Data Packet is not multiple of 8 bytes, Encryption Padding bytes are added so that encryption size becomes multiple of 8 bytes. The size of the Encryption Padding bytes is from 0 to 7⁶⁷. The value of each padding byte is 00₁₆.

A Data block and Encryption Padding bytes are encrypted according to the value of EMI, and becomes a Protected Content. The Size of the Protected Content is 8 x N bytes (N= 1, 2,.. 63). Protected Content Packet consists of 8 bytes PCP header and a Protected Content. When the size of a Protected Content Packet is not equal to 512 bytes, Alignment Padding bytes are added so that PCP header is located at every 512 bytes in the Protected Frame. The size of the Alignment Padding bytes is 8 x M bytes (M= 0, 1,.. 62). Alignment Padding bytes shall be used only when next Protected Content Packet has different EMI or CT during a Protected Frame transmission.

Following figure shows the generic construction of Protected Content Packet in the Protected Frame.

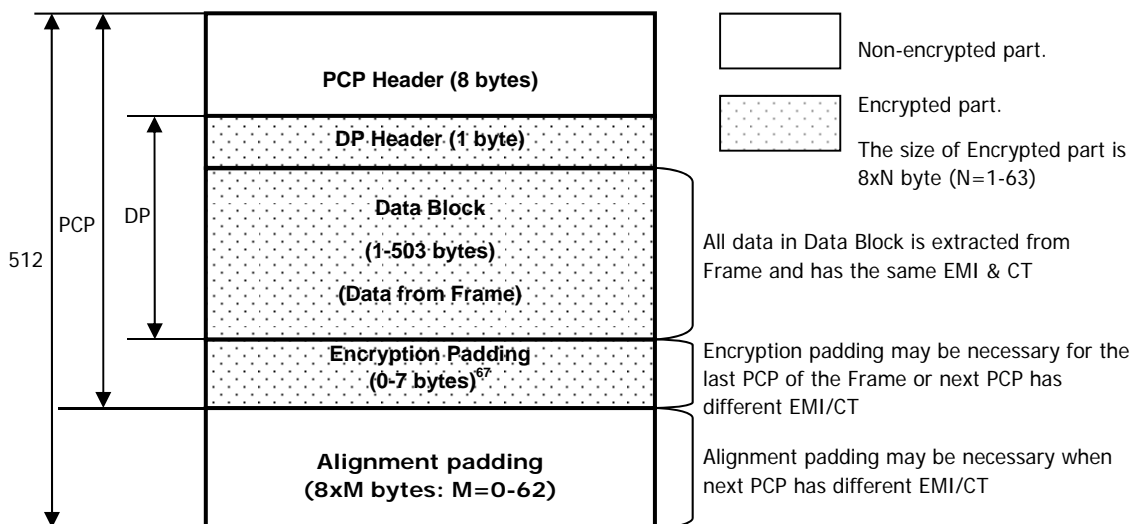

Figure 36 Generic Construction of Protected Content Packet in the Protected Frame

D.2.4 N_C Update Process

For DTCP-AC, the N_C shall be updated after a Protected Frame is transmitted. If the size of a Protected Frame is larger than 32,768PCPs (16Mbytes), the N_C shall be updated every 32,768PCPs transmission. N_C is updated by incrementing it by 1 mod 2⁶⁴.

If a device has DTCP functionality for both isochronous transmission as a source device and AC as a Producer, the device may use different N_C for an isochronous transmission and AC. If a Producer has plural asynchronous output plugs, the Producer may use different N_C for each plug.

D.2.5 Duration of Exchange Keys

The K_X for isochronous transmission shall also be used for K_X for AC. K_X for AC shall not be expired as long as AC is established. When all ACs of the Producer are broken, K_X of AC is recommended to be expired as long as the Producer is stopping all isochronous output as a source device.

⁶⁷ In case of AES-128 optional cipher, when the size of Data Packet is 2 through 15 bytes, the size of Encryption Padding bytes becomes 1 to 14 bytes. When the size of Data Packet is 16 through 504 bytes, Encryption Padding becomes 0 to 7 bytes.

D.2.6 Frame Transfer type

AC specifies two types of frame transfers. They are file-type transfers and stream-type transfers.

D.2.6.1 File-type Transfer

In file-type transfers, all of the selected frame data in the Producer is transmitted to the Consumer. DTCP-AC described in this Appendix is applied to file-type transfers.

D.2.6.2 Stream-type Transfer

DTCP-AC for stream-type transfers is a NOT ESTABLISHED feature³ that is not currently specified.

D.3 Embedded CCI

Embedded CCI is carried as part of the content stream. Many content formats including MPEG have fields allocated for carrying the CCI associated with the stream. The definition and format of the CCI is specific to each content format. Information used to recognize the content format should be embedded within the content.

D.4 AKE Command Extensions

D.4.1 Status Field

In the AKE command, status field is used to query the status of the target device. A Producer shall not use the value of 0010₂ (No isochronous output) and 0011₂ (No point to point connection) when the Producer has at least one AC on its Serial Bus Asynchronous Output Plugs. When a Producer does not have any AC on its Serial Bus Asynchronous Output Plugs, the Producer may use these values according to the rules described in section **Error! Reference source not found.**

As for the usage of status field of CONTENT_KEY_REQ subfunction for DTCP-AC and SET_DTCP_MODE subfunction, refer to section **Error! Reference source not found.** and **Error! Reference source not found.** respectively.

Appendix E Content Management Information (CMI)

E.1 General

E.1.1 Purpose and Scope

Content Management Information (CMI) refers to usage rules associated with the content (e.g. CCI, DOT, Copy-count, etc.) which can be transmitted over DTCP as defined by DTLA.

The CMI is sent out in CMI Descriptor where each CMI Descriptor has its own ID, format and rules as defined by DTLA. Each unique CMI Descriptor ID refers to specific set of CMI. CMI Field consists of one or more CMI Descriptor. Source devices and Sink devices supporting CMI shall follow the corresponding rules for each CMI Descriptor defined in the following sections. Source devices shall not send any CMI Descriptor which is not supported by themselves except the case of the DTCP Bus Bridging and the case when DTLA approves.

Note that new CMI Descriptor may be additionally defined and transmitted with the CMI Descriptors currently defined. CMI descriptors allow for future expandability by either defining new descriptors or expansion of a currently defined descriptor. In the event that additional usage rule is added to a currently defined descriptor, the length of the CMI Descriptor Data field may be extended and the descriptor byte length value may be changed. If this occurs, currently defined fields in the CMI Descriptor Data shall not be altered to ensure backward compatibility. All devices shall be designed so that any change to the descriptor byte length value that results from an extension of the CMI Descriptor Data field shall not prevent access to contents of the CMI Descriptor Data field defined as of the time the device is manufactured.

Here is one example. Suppose CMI Descriptor-X has a set of usage rules. CMI Descriptor-Y is defined with a set of other usage rules later. A source device which supports the CMI Descriptor-X and CMI Descriptor-Y sends both CMI Descriptor-X and CMI Descriptor-Y. When a sink device does not support CMI Descriptor-Y the sink device may use the received content in accordance with the usage rules defined in the CMI Descriptor-X if the sink device supports the CMI Descriptor-X.

Here is another example. Suppose CMI Descriptor-A has a set of usage rules. CMI Descriptor-B has another set of usage rules. CMI Descriptor-C is defined with a set of other rules later. A source device which supports all CMI Descriptors sends CMI Descriptor-A and CMI Descriptor-C. When a sink device which supports both CMI Descriptor-A and CMI Descriptor-C the sink device may use the received content in accordance with the usage rules defined in CMI Descriptor-C if the sink device supports CMI Descriptor-C. In this case the sink device shall ignore the usage rules defined in the CMI Descriptor-A.

Here is another example. Suppose CMI Descriptor-D has a set of usage rules D-1, D-2 and D-3. CMI Descriptor-E with a set of usage rules D-1, D-2, D-3 and D-4 is defined later and the usage rule D-4 defines that a sink device may ignore D-4. A new source device which supports both old CMI Descriptor-D and new CMI Descriptor-E can send both CMI Descriptor-D and CMI Descriptor-E. An old sink device which supports CMI Descriptor-D only can use the received content in accordance with old CMI Descriptor-D.

E.1.2 General Rules for Source Devices

The following are the rules for source devices that support CMI⁶⁸:

- Source devices shall not send content associated with a CMI Field before getting some indication that a sink device supports CMI, such as the CMI_REQ subfunction-[CAPABILITY REQ2 subfunction, or some other method.](#)
- Source devices shall use the Alternate Content Key for the encryption of content associated with a CMI Field.
- When source devices send more than one CMI Descriptors in a CMI Field, the following rules shall be kept:
 - CMI Descriptors shall be sent in ascending order of CMI Descriptor ID.
 - The same CMI Descriptor shall not be contained in a single CMI Field. CMI Descriptors shall be concatenated without any space.
 - The set of CMI Descriptor IDs shall not be changed while the value of CMI Descriptor Data may be changed during content transmission.
- When source devices send multiple streams with MPEG-TS using DTCP_descriptors, CMI Descriptors which provide a single set of content management information for all streams, such as the CMI Descriptor 1, shall not be used unless information in the CMI Descriptor is consistent with information in the DTCP_descriptor of any streams.

E.1.3 General Rules for Sink Devices

The following are the rules for sink devices that support CMI:

- When sink devices receive content associated to a CMI Field, they shall process the content in accordance with the usage contained in the CMI Field. Unless specified by a CMI Descriptor rule, sink devices shall use only the information in CMI Field as usage rules.
- When sink devices receive a CMI Field that contains more than one CMI Descriptor,
 - Sink devices shall use the usage rules of only one of the supported CMI Descriptors and ignore the other CMI Descriptors. Sink devices may select any one of the supported CMI Descriptors.
 - When sink devices receive a CMI Field that does not contain the CMI Descriptor 0, they shall discard the content.
- For Bus Bridge devices, even if they support none of the received CMI Descriptor(s) they may output the content with the same CMI Field.
- When a sink device does not support any of the CMI Descriptors in a CMI Field it shall discard all content associated to the CMI Field.

E.2 CMI Field

CMI Field may consist of one or more CMI Descriptors. Every CMI Descriptor shall be one byte aligned. CMI Descriptors shall be contained in ascending order of CMI Descriptor ID.

An example of CMI Field is described in the following figure.

	msb							lsb
CMI Field[0..M]	CMI Descriptor X							
CMI Field [M+1..N]	CMI Descriptor Y							

CMI Field [0..M]: Contains CMI Descriptor X format data.

CMI Field [M+1..N]: Contains CMI Descriptor Y format data.

⁶⁸ Note that device supporting CMI only are not interoperable with devices which do not support CMI, and not fully interoperable if the same CMI Descriptor is not supported.

E.3 CMI Descriptor Descriptions

E.3.1 CMI Descriptor General Format

The general format of CMI Descriptor except CMI Descriptor 0 is as follows:

	msb						lsb
CMI Descriptor ID [0]	ID						
Extension [0]	Extension						
Byte Length [0]	Byte length of CMI Descriptor Data (16 bits)						
Byte Length [1]							
CMI Descriptor Data [0]	Usage Rules						
-							
CMI Descriptor Data [N-1]							

CMI Descriptor ID [0]: Contains ID field. DTLA assigns ID.

Extension [0]: Is specified by each CMI Descriptor.

Byte Length [0..1]: Denotes byte length of Usage Rules field, where it is less than or equal to 64KB.

CMI Descriptor Data [0..N-1]: Represents usage rules and there is no usage rule when Byte Length field is zero.

When sink devices receive CMI Descriptor which has the Extension field of non-zero value, sink devices shall regard it as unsupported CMI Descriptor, and shall ignore the following fields. Note that this CMI Descriptor may have extended Byte Length field by using Extension field that may be more than 64KB.

E.3.2 CMI Descriptor 0

E.3.2.1 CMI Descriptor 0 Format

The format of CMI Descriptor 0 is as follows:

	msb							lsb
CMI Descriptor ID [0]	ID (00 ₁₆)							
Extension [0]	00 ₁₆							
Byte Length [0]	Byte length of CMI Descriptor 0 data							
Byte Length [1]								
CMI Descriptor Data [0]	Reserved (0000 ₂)				C_T			

C_T field indicates the type of content that is associated to this CMI Descriptor 0 and has the following values:

Value	Description
0000 ₂	Audiovisual content
0001 ₂	Audio content
0010 ₂ ..1111 ₂	Reserved

Table 42 C_T Field

E.3.2.2 Rules for Source Devices

Source devices shall support and always insert this CMI Descriptor.

E.3.2.3 Rules for Sink Devices

When sink devices use this CMI Descriptor, sink devices shall behave as Format-non-cognizant sink functions.

Sink devices with rendering functions shall support this CMI Descriptor.

Sink devices shall regard CMI Descriptor 0 as unsupported when the sink device does not support the value in the C_T field.

E.3.3 CMI Descriptor 1

It is recommended to use this CMI Descriptor 1 as the baseline CMI Descriptor unless another CMI Descriptor is required as the mandatory CMI Descriptor.

CMI Descriptor 1 is used only with audiovisual content.

E.3.3.1 CMI Descriptor 1 Format

The format of CMI Descriptor 1 is as follows:

	msb						lsb
CMI Descriptor ID [0]	ID (01 ₁₆)						
Extension [0]	00 ₁₆						
Byte Length [0]	Byte length of CMI Descriptor 1 data						
Byte Length [1]							
CMI Descriptor Data [0]	res(1 ₂)	RM	Retention_State		EPN	DTCP_CCI	
CMI Descriptor Data [1]	res(111 ₂)		DOT	AST	ICT	APS	
CMI Descriptor Data [2]	Reserved (0000 ₂)				CC		

ID field has the value of one for the CMI Descriptor 1.

res are fields for future extension where source devices shall set the value one for every bit of the res field. Sink devices shall use value of reserved fields to calculate K_c in order that they can accommodate any future changes.

Reserved is a field for future extension where source devices shall set the value zero for every bit of the reserved field. Sink devices shall use value of reserved fields to calculate K_c in order that they can accommodate any future changes.

RM field indicates Retention_Move_mode as described in section B.2.1.

Retention_State field indicates Retention_State as described in section B.2.1.

EPN field indicates Encryption Plus Non-assertion as described in section B.2.1.

DTCP_CCI field indicates DTCP_CCI as described in section B.2.1.

AST field indicates Analog_Sunset_Token as described in section B.2.1.

ICT field indicates Image_Constraint_Token as described in section B.2.1.

APS field indicates analog copy protection information as described in section B.2.1.

DOT field indicates Digital Only Token as described in section B.2.1.

CC field indicates Copy-count. Only when EMI is Mode B, DTCP_CCI is Copy-one-generation (10₂), Retention_Move_mode bit is zero (0₂), and this field is non-zero, this field is valid. In other conditions, this field is invalid. This field is set to a value greater than zero based on the request by CMI_REQ command or some other method otherwise it is set to zero.

CC	Meaning
0000 ₂	Invalid
Others	N copies are allowed

E.3.3.2 Rules for Source Devices

When source devices do not use CC field, they shall set CC field to zero.

When source devices send this CMI Descriptor, they may transmit MPEG-TS content without DTCP_descriptors unless the other CMI Descriptor requires insertion of DTCP_descriptor⁶⁹.

Source devices shall not use this CMI Descriptor when transmitting MPEG-TS content with DTCP descriptor and value of this CMI Descriptor is inconsistent with value of DTCP_descriptor in combination with EMI (for example when the MPEG-TS content consists of multiple programs or the content consists of a single program that includes multiple DTCP_descriptors).

E.3.3.3 Rules for Sink Devices

When sink devices receive a content stream with invalid condition about CC field as specified in E.3.3.1, they shall ignore CC field.

E.3.4 CMI Descriptor 2

E.3.4.1 CMI Descriptor 2 Format

The format of CMI Descriptor 2 is as follows:

	msb						lsb
CMI Descriptor ID [0]	ID (02 ₁₆)						
Extension [0]	00 ₁₆						
Byte Length [0]	Byte length of CMI Descriptor 2 data						
Byte Length [1]							
CMI Descriptor Data [0]	CC			Reserved (0000 ₂)			

ID field has the value of two for the CMI Descriptor 2.

CC field indicates CC as described in section E.3.3.1

Reserved field is the area for future extension. Source devices shall set zero to every bit in this field. Sink devices shall use value of reserved field to calculate K_C in order that they can accommodate any future changes.

E.3.4.2 Rules for Sources Devices

Source devices shall not insert this CMI Descriptor except when transmitting content stream in MPEG-TS format. When source devices use this CMI Descriptor source devices shall insert the DTCP_descriptor in the content stream in accordance with the Appendix B. For clarification, both CMI Descriptor 1 and CMI Descriptor 2 may be sent in the CMI Field.

When source devices do not use CC field, they shall set CC field to zero. The CC field shall not be used for content other than audiovisual content.

Source devices shall use this CMI Descriptor 2 when transmitting content in MPEG-TS format with DTCP_descriptor.

E.3.4.3 Rules for Sink Devices

When sink devices use this CMI Descriptor, associated content shall be handled based on the usage rule information contained in the DTCP_descriptor in accordance with the Appendix B.

CC field shall be handled as it is contained in the DTCP_descriptors within every program info loop of the PMT. When sink devices receive a content stream with a CC field indicates invalid condition as specified in E.3.3.1 they shall ignore CC field.

If neither the DTCP_descriptor nor Embedded CCI is detected, sink devices shall not use this CMI Descriptor.

⁶⁹ Note that there are technologies that require the DTCP output to set the DTCP_descriptor. In that case the CMI Descriptor 2 is also used (see E.3.4.2).